

CORE ELECTRIC



INDUSTRIAL EQUIPMENT

REACH NEW HEIGHTS

3000 - 6500 LBS.

SPECIFICATIONS



7FBCU15-18 | 8FBCU20-32 | 8FBCU20-25-COMP | 8FBCHU25

CLASS

1

ELECTRIC MOTOR RIDERS

ToyotaForklift.com

CAPACITY
3000 - 6500 LBS.

MAXIMUM FORK HEIGHT
131.5 IN.

LOAD CENTER
24 IN.

INDUSTRIES



Beverage



Factory



Food Processing



Food Storage



General Manufacturing



General Warehousing



Retail

STANDARD FEATURES

SAFETY

- System of Active Stability™ (SAS)
 - Active control rear stabilizer
 - Active mast function controller
- Operator Presence Sensing System (OPSS)
- Key lowering interlock
- Asbestos-free brakes
- Double-action, foot-activated parking brake
- Electric horn
- Manual return to neutral

PERFORMANCE

- AC drive system (MOSFET Transistor)
- AC hydraulic lift system (MOSFET Transistor)¹
- UL-approved model type “E”
- Three forms of energy regeneration
 - Coast control
 - Plug braking
 - Foot braking
- Digital (LCV) multifunction display
 - Time & date
 - Speedometer
 - Multifunction hour meter
 - Battery capacity indicator
 - Overdischarge warning (lift interrupt)
 - Parking brake indicator
 - Low-speed-setting switch
 - Direction indicator
 - Mast tilt indicator
- Maximum speed limiter
- Built-in analyzer
- Self-diagnostics
- Power select functions (S.P.H.)
- 3-way hydraulic control valve
- Auto shut-off (programmable after 15 minutes)
- Travel power control (acceleration)

BODY/EXTERIOR DESIGN

- Wide-view 2-stage mast (V)
- Punched plate entry/exit step
- 48" load backrest extension
 - With angled tie bar
- Tapered forks
- Smooth or treaded cushion tires
- Wide-view carriage bars
- Drawbar pin
- Tie-down hooks
- Adjustable front headlights
- ORS vinyl non-suspension seat
- ORS 4-way adjustable full-suspension seat (8 series style, multiple options available)¹
- Retractable seatbelt
- 85° wide-opening battery hood
- Overhead guard
- SB 350 battery connector (gray)
- 26.8" battery compartment (3000 - 3500 lbs.)
- 27.4" battery compartment (4000 - 5000 lbs.)
- 30.5" battery compartment (4000 - 5500 lbs.)
- 34.3" battery compartment (6000 - 6500 lbs.)²

OPERABILITY & ERGONOMICS

- Strategically configured instrument display
- Hydrostatic (On Demand) power steering
- Dual operator assist grips
- SAS automatic fork-leveling control
- Electric directional shift control
- Memory-tilt steering column
- 11.8"-dia. two-spoke steering wheel¹
- Cowl-mounted hydraulic controls
- Heavy-duty non-slip floor mat
- Dash-integrated pen/pencil holder
- Hood-integrated clipboard
- Dash-mounted cup holder

SERVICEABILITY

- AC drive motor (no brushes or commutator)
- AC hydraulic motor (no brushes or commutator)¹
- Easy-access hydraulic motor
- Bolt-on overhead guard
- Easy-access no tools required floorboard
- Battery compartment hood assist dampers
- Planned maintenance indicator
- Easy-access controller
- CAN-bus controller wiring

¹ Option only available on 8-Series truck.
² 7000 lb. model is available for the beverage industry only, and requires engineering approval before ordering.

OPTIONAL EQUIPMENT³

LOAD HANDLING

- Wide visible mast (V)
- Full free-lift 2-stage mast (FV)
- Full free-lift 3-stage mast (FSV)
- Full free-lift 4-stage mast (QFV)²
- Tilt cylinder boots
- Mast tilt (Bottler's tilt forward)
- Tapered forks
- Fully tapered & polished forks
- Fork bar (wide carriage)
- High load backrest
- Load-handling chopper¹
- Performance hydraulic package¹
- Side hosing termination
- Less mast & forks³
- Less forks
- Less backrest
- 36" black forks²

LOAD HANDLING (HOSE & VALVE ASSEMBLY)

- 3-way valve (multiple options available)
- Cascade sideshifter (multiple options available)
- Rightline sideshifter (multiple options available)
- 4-way valve (multiple options available)
- Cascade integral sideshifter (FSV mast only)
- Cascade integral sideshifting fork positioner (FSV mast only)
- Hydraulic quick disconnects (single & dual)
- TOYOTA integral sideshifter (multiple options available)
- Clamp release interlock²

LIGHTS & INDICATORS

- Front combination lights
- LED front combination headlights
- Rear combination lights
- LED rear combination lights
- Rear working light
- LED work light
- Low-profile mast-mounted LED headlights²
- Low-profile mast-mounted LED RR work light²
- Operator compartment light
- Strobe light (multiple options available)
- LED strobe light (multiple options available)
- Key off/headlights off system²
- Adjustable volume back up alarm (smart alarm)
- Back up alarm
- Back up buzzer²
- Armrest horn²
- Transistorized horn
- Fire extinguisher 2.5 lb. upgrade (including bracket)
- Fire extinguisher 5 lb. upgrade (including bracket)
- Reverse activated work light²

TELEMATICS (ONLY ONE T-MATICS OPTION MAY BE ORDERED PER TRUCK)²

- T-Matics mobile
 - CDMA network (U.S. only)
 - GSM network (Canada/U.S.)
- T-Matics command
 - iRF, Proximity Card, CAN
 - iRF, iButton, CAN
- Wi-Fi, Proximity Card, CAN
- Wi-Fi, iButton, CAN

BODY

- Left-hand shift lever²
- Pre-delivery inspection
- Mini-levers with ErgoShift²
- Joystick²
- Synchronized steering²
- Rearview mirrors (left & right sides)
- Plastic mirrors
- Skid plate
- Travel speed/acceleration control system²
- Power shut-down button²
- Battery slide-out
- Battery roll-out²
- Euro connector²
- Rear pillar assist grip with horn²
- Touchpad keyless entry system²
- Impact sensor²
- Battery compartment side panels
- Drive-in rack overhead guard
- Auto height select²
- String cutter²
- Pencil/tape holder
- Keyless ignition
- 12-Volt power supply (9-10 amps)
- 12-Volt power supply harness extension²
- Anti-static strap
- Fully oil-charged lift cylinder²
- Steering wheel with knob
- Swivel seat (multiple options available)
- ORS semi-suspension seat (multiple options available)
- Vinyl ORS Araco seat (multiple options available)¹
- Orange seatbelt
- Lowered 83.3" – 84.9" overhead guard height²
- Lowered 81.9" – 83.5" (±1.57") overhead guard with low-profile seat²
- Without UL label
- Special paint (one or two color only)
- Hydraulic component guard for cascade sideshifters²
- Cloth 20° swivel seat (requires option code G40C)³
- Optional battery connector colors (multiple options available)
- Polycarbonate overhead guard cover
- Operator cooling fan²
- Exclusive key²
- Cascade integral sideshifter hose guard
- French decals

Optional Equipment, continued

CHASSIS

- Motor brush wear/overheat protection device¹
 - Electronic Hydraulic Power Steering (EHPS)¹
 - Power steering hose guard
 - Seat brake¹
 - EZ Pedal (foot directional control)
 - Wide tire & wide tread (front)¹
 - Inching EPROM²
-

WHEELS & TIRES

- Smooth, white, non-marking tires (front & rear)
 - Treaded, non-marking tires (front & rear)
 - Smooth, black tires (front & rear)
 - Smooth, non-marking tires (front & rear)
 - Treaded tires (front & rear)²
 - Wide tread (front tires)²
 - Wide steer tire (6")²
-

SPECIAL MODEL

- Compact specification (27.4" battery compartment)²
- High-capacity frame (7000 lb.), for beverage industry only²
- I.T.A. Class III carriage for QFV mast (requires TR49)²
- UL-approved model
 - Type "EE"
 - Type "ES"
- Cold storage model
 - Type "20S"
- Rustproof specification²
- 48-Volt model

¹ Option only available on 7-Series truck.
² Option only available on 8-Series truck.
³ Refer to FL Manual for option conflicts.

TRUCK SPECIFICATIONS

MODEL NUMBERS

GENERAL DATA				7FBCU15		7FBCU18			
Load Capacity		lb (kg)		3000 (1500)		3500 (1750)			
Power Type (battery)	Voltage	V	36	48	36	48			
Battery Compartment Length			26.8		26.8				
Operator Position			Seated Rider		Seated Rider				
Tire Type	Front / Rear		Cushion / Cushion		Cushion / Cushion				
Wheels (x = driven)	Front / Rear		2x / 2		2x / 2				
EXTERIOR DIMENSIONS				7FBCU15		7FBCU18			
A	Maximum Fork Height (top of forks)	in (mm)	131 (3335)		131 (3335)				
B	Free-Lift (top of forks)	in (mm)	5.7 (145)		5.7 (145)				
C	Fork Size (T x W x L)	in (mm)	1.4 x 4 x 42 (35 x 100 x 1070)		1.4 x 4 x 42 (35 x 100 x 1070)				
D	Tilt Range (forward / backward)	deg	6 / 10		5 / 10				
E	Length to Fork Face	in (mm)	76.8 (1950)		76.8 (1950)				
F	Overall Width	in (mm)	37 (945)		37 (945)				
G	Mast Lowered Height	in (mm)	83.1 (2110)		83.1 (2110)				
H	Mast Extended Height (top of load backrest)	in (mm)	179.3 (4555)		179.3 (4555)				
I	Overhead Guard Height	in (mm)	86.4 (2195)		86.4 (2195)				
J	Turning Radius (inside / outside)	in (mm)	66.3 (1685)		66.3 (1685)				
K	Load Distance ¹	in (mm)	15.8 (400)		15.8 (400)				
L	Basic Right-Angle Stacking Aisle Width ²	in (mm)	82.1 (2085)		82.1 (2085)				
PERFORMANCE DATA				7FBCU15		7FBCU18			
Speeds ³	Maximum Travel (fwd. / rev.)	Full Load	mph (km/h)	9.0 (14.5)	10.9 (17.5)	8.7 (14)	10.6 (17)		
		No Load	mph (km/h)	9.3 (15)	11.2 (18)	9.3 (15)	11.2 (18)		
	Lifting	Full Load	fpm (mm/sec)	61 (310)	85 (430)	61 (310)	81 (410)		
		No Load	fpm (mm/sec)	110 (560)	142 (720)	110 (560)	142 (720)		
	Lowering	Full Load	fpm (mm/sec)	98 (500)		98 (500)			
		No Load	fpm (mm/sec)	108 (550)		108 (550)			
Drawbar Pull	Full Load / No Load	3-Min. Rating	lb (kg)	2090 (950) / 1700 (770)		2080 (940) / 1670 (760)			
		3-Min. Rating	lb (kg)	2090 (950) / 1700 (770)		2080 (940) / 1670 (760)			
		60-Min. Rating	lb (kg)	540 (250) / 580 (260)		530 (240) / 580 (260)			
Gradeability [*]	Full Load / No Load	3-Min. Rating	%	20 / 21		18 / 20			
		3-Min. Rating	%	20 / 21		18 / 20			
		60-Min. Rating	%	8 / 13		7 / 13			
TRUCK WEIGHTS				7FBCU15		7FBCU18			
Total Weight		lb (kg)	4930 (2240)		5200 (2365)				
Weight Distribution ⁴	Full Load (front / rear)	lb (kg)	8360 (3910) / 1410 (660)		9230 (4325) / 1310 (620)				
	No Load (front / rear)	lb (kg)	2880 (1305) / 3890 (1765)		2830 (1285) / 4210 (1910)				
TIRES				7FBCU15		7FBCU18			
Tires	Number (front / rear)		2 / 2		2 / 2				
	Size (front / rear)		18 x 6 x 12-1 / 8 / 14 x 4-1 / 2x8		18 x 6 x 12-1 / 8 / 14 x 4-1 / 2x8				
Wheelbase		in (mm)	48 (1220)		48 (1220)				
Tread Width (front / rear)		in (mm)	31.3 (795) / 32.3 (820)		31.3 (795) / 32.3 (820)				
Underclearance (full load)	Minimum <Drive Axle>	in (mm)	2.6 (65)		2.6 (65)				
	Center of Wheelbase	in (mm)	3.1 (80)		3.1 (80)				
Brake	Service (foot) / Parking		Hydraulic / Hand		Hydraulic / Hand				
POWER SYSTEM				7FBCU15		7FBCU18			
Battery	Voltage / Capacity (STD)	V / Ah	36 / 680		48 / 510		36 / 680	48 / 510	
	6-Hour Rating (high)	V / Ah	36 / 880		48 / 660		36 / 880	48 / 660	
Electric Motors	Drive	kW	6.3		8.3		6.3	8.3	
	Load Handling	kW	7.4		10.4		7.4	10.4	
	Power Steering		0.7		0.9		0.7	0.9	
Control Type	Drive		Transistor Inverter		Transistor Inverter				
	Load Handling		Electromagnetic Contactor		Electromagnetic Contactor				
	Power Steering		Electromagnetic Contactor		Electromagnetic Contactor				
Auxiliary Hydraulic Function Specifications (for attachments) ⁵	Max. Operating Pressure	psi (kg/cm ²)	2280 (160)		2280 (160)				
	Max. Flow Rate	w/out Chopper	gpm (lpm)	12.1 (45.8)		16.3 (61.7)		12.1 (45.8)	16.3 (61.7)
		w/ Chopper		Reference Page I-B-14 for Flow & Pressure Specifications Chart					

* Computed values.

1 At centerline of front axle to front face of forks.
 2 Add load length & clearance.
 3 Reference page I-B-4 for S & P mode travel speeds (loaded & unloaded) in FL Manual.

4 With standard battery.
 5 Values taken at Hydraulic Control Valve. Does not take in to consideration losses through mast plumbing (hosing, fittings, QDs, etc.).

GENERAL DATA				8FBCU20		8FBCU20-COMP		8FBCU25		8FBCU25-COMP	
Load Capacity		lb (kg)		4000 (2000)		4000 (2000)		5000 (2500)		5000 (2500)	
Power Type (battery)	Voltage	V		36	48	36	48	36	48	36	48
Battery Compartment Length		in		30.5		27.4		30.5		27.4	
Operator Position				Seated Rider		Seated Rider		Seated Rider		Seated Rider	
Tire Type	Front / Rear			Cushion / Cushion		Cushion / Cushion		Cushion / Cushion		Cushion / Cushion	
Wheels (x = driven)	Front / Rear			2x / 2		2x / 2		2x / 2		2x / 2	
EXTERIOR DIMENSIONS				8FBCU20		8FBCU20-COMP		8FBCU25		8FBCU25-COMP	
A	Maximum Fork Height (top of forks)	in (mm)		131.5 (3340)		131.5 (3340)		131.5 (3340)		131.5 (3340)	
B	Free-Lift (top of forks)	in (mm)		6.1 (155)		6.1 (155)		6.1 (155)		6.1 (155)	
C	Fork Size (T x W x L)	in (mm)		1.6 x 5 x 42 (40 x 125 x 1070)		1.6 x 5 x 42 (40 x 125 x 1070)		1.6 x 5 x 42 (40 x 125 x 1070)		1.6 x 5 x 42 (40 x 125 x 1070)	
D	Tilt Range (forward / backward)	deg		6 / 8		6 / 8		6 / 8		6 / 8	
E	Length to Fork Face	in (mm)		81.5 (2170)		79.9 (2030)		84.3 (2140)		82.7 (2100)	
F	Overall Width	in (mm)		41.9 (1065)		41.9 (1065)		41.9 (1065)		41.9 (1065)	
G	Mast Lowered Height	in (mm)		83.3 (2115)		83.3 (2115)		83.3 (2115)		83.3 (2115)	
H	Mast Extended Height (top of load backrest)	in (mm)		179.5 (4560)		179.5 (4560)		179.5 (4560)		179.5 (4560)	
I	Overhead Guard Height	in (mm)		88 (2235)		88 (2235)		88 (2235)		88 (2235)	
J	Turning Radius (inside / outside)	in (mm)		70.5 (1790)		68.5 (1740)		70.9 (1800)		68.9 (1750)	
K	Load Distance ¹	in (mm)		16.7 (425)		16.7 (425)		16.7 (425)		16.7 (425)	
L	Basic Right-Angle Stacking Aisle Width ²	in (mm)		87.2 (2215)		85.2 (2165)		87.6 (2225)		85.6 (2170)	
PERFORMANCE DATA				8FBCU20		8FBCU20-COMP		8FBCU25		8FBCU25-COMP	
				36V	48V	36V	48V	36V	48V	36V	48V
Speeds ³	Maximum Travel (fwd. / rev.)	Full Load	mph (km/h)	9.9 (16)	11.5 (18.5)	9.9 (16)	11.5 (18.5)	9.6 (15.5)	11.5 (18.5)	9.6 (15.5)	11.5 (18.5)
		No Load	mph (km/h)	11.2 (18)	11.5 (18.5)	11.2 (18)	11.5 (18.5)	10.9 (17.5)	11.5 (18.5)	10.9 (17.5)	11.5 (18.5)
	Lifting	Full Load	fpm (mm/sec)	67 / 340	89 / 450	67 / 340	89 / 450	59 (300)	79 (400)	59 (300)	79 (400)
		No Load	fpm (mm/sec)	106 / 540	130 / 660	106 / 540	130 / 660	106 (540)	130 (660)	106 (540)	130 (660)
	Lowering	Full Load	fpm (mm/sec)	98 (500)		98 (500)		98 (500)		98 (500)	
		No Load	fpm (mm/sec)	98 (500)		98 (500)		98 (500)		98 (500)	
Drawbar Pull	Full Load / No Load	3-Min. Rating	lb (kg)	3320 (1510) / 2140 (970)		3320 (1510) / 2140 (970)		3290 (1490) / 2010 (910)		3290 (1490) / 2010 (910)	
		3-Min. Rating	lb (kg)	3320 (1510) / 2140 (970)		3320 (1510) / 2140 (970)		3290 (1490) / 2010 (910)		3290 (1490) / 2010 (910)	
		60-Min. Rating	lb (kg)	1610 (730) / 1700 (770)		1610 (730) / 1700 (770)		1580 (720) / 1690 (760)		1580 (720) / 1690 (760)	
Gradeability [*]	Full Load / No Load	3-Min. Rating	%	25 / 23		25 / 23		21 / 19		21 / 19	
		3-Min. Rating	%	25 / 23		25 / 23		21 / 19		21 / 19	
		60-Min. Rating	%	11 / 19		11 / 19		9 / 17		9 / 17	
TRUCK WEIGHTS				8FBCU20		8FBCU20-COMP		8FBCU25		8FBCU25-COMP	
Total Weight		lb (kg)		6260 (2840)		6390 (2840)		6960 (3155)		7170 (3250)	
Weight Distribution ⁴	Full Load (front / rear)	lb (kg)		10800 (5070) / 1870 (860)		10930 (5130) / 1870 (860)		12410 (5850) / 1950 (900)		12550 (5910) / 2020 (930)	
	No Load (front / rear)	lb (kg)		3620 (1640) / 5050 (2290)		3750 (1700) / 5050 (2290)		3440 (1560) / 5920 (2685)		3580 (1625) / 5990 (2715)	
TIRES				8FBCU20		8FBCU20-COMP		8FBCU25		8FBCU25-COMP	
Tires	Number (front / rear)			2 / 2		2 / 2		2 / 2		2 / 2	
	Size (front / rear)			21 x 7 x 15 / 16 x 5 x 10.5		21 x 7 x 15 / 16 x 5 x 10.5		21 x 7 x 15 / 16 x 5 x 10.5		21 x 7 x 15 / 16 x 5 x 10.5	
Wheelbase		in (mm)		51 (1295)		51 (1295)		51 (1295)		51 (1295)	
Tread Width (front / rear)		in (mm)		35 (890) / 36 (915)		35 (890) / 36 (915)		35 (890) / 36 (915)		35 (890) / 36 (915)	
Underclearance (full load)	Minimum <Mast>	in (mm)		3.0 (75)		3.0 (75)		3.0 (75)		3.0 (75)	
	Center of Wheelbase	in (mm)		3.9 (100)		3.9 (100)		3.9 (100)		3.9 (100)	
Brake	Service (foot) / Parking Brake			Hydraulic / Foot		Hydraulic / Foot		Hydraulic / Foot		Hydraulic / Foot	
POWER SYSTEM				8FBCU20		8FBCU20-COMP		8FBCU25		8FBCU25-COMP	
				36V	48V	36V	48V	36V	48V	36V	48V
Battery	Voltage / Capacity (STD)	V / Ah		36 / 1020	48 / 765	36 / 880	48 / 640	36 / 1020	48 / 765	36 / 880	48 / 640
	6-Hour Rating (High)	V / Ah		36 / 1320	48 / 990	36 / 1210	48 / 880	36 / 1320	48 / 990	36 / 1210	48 / 880
Electric Motors	Drive	kW		10.8	14.8	10.8	14.8	10.8	14.8	10.8	14.8
	Load Handling	kW		11.3	15.1	11.3	15.1	11.3	15.1	11.3	15.1
	Power Steering										
Control Type	Drive			Transistor Inverter		Transistor Inverter		Transistor Inverter		Transistor Inverter	
	Load Handling			Transistor Inverter		Transistor Inverter		Transistor Inverter		Transistor Inverter	
	Power Steering			Transistor Inverter		Transistor Inverter		Transistor Inverter		Transistor Inverter	
Auxiliary Hydraulic Function Specifications (for attachments) ⁵	Max. Operating Pressure	psi (kg/cm ²)		2580 (181)		2580 (181)		2580 (181)		2580 (181)	
	Max. Flow Rate	gpm (lpm)		11.04		11.04		11.04		11.04	
Reference Page I-A-29 For Flow & Pressure Specifications Chart											

* Computed values.

³ Units ordered with A30H UL "EE" rating will have the same performance characteristics as the UL "E"-rated models. Values indicated reflect speed in H mode. (Reference page I-A-29 in FL Manual for S & P mode travel speeds loaded & unloaded).

⁴ With standard battery.

⁵ Values taken at Hydraulic Control Valve. Does not take in to consideration losses through mast plumbing (hosing, fittings, QDs, etc.).

¹ At centerline of front axle to front face of forks.
² Add load length & clearance.

TRUCK SPECIFICATIONS

MODEL NUMBERS

GENERAL DATA				8FBCHU25		8FBCHU28		8FBCHU30		8FBCHU32	
Load Capacity		lb (kg)		5000 (2500)		5500 (2750)		6000 (3000)		6500 (2950)	
Power Type (battery)	Voltage	V		36	48	36	48	36	48	36	48
Battery Compartment Length		in		34.3		30.5		34.3		34.3	
Operator Position				Seated Rider		Seated Rider		Seated Rider		Seated Rider	
Tire Type	Front / Rear			Cushion / Cushion		Cushion / Cushion		Cushion / Cushion		Cushion / Cushion	
Wheels (x = driven)	Front / Rear			2x / 2		2x / 2		2x / 2		2x / 2	
EXTERIOR DIMENSIONS				8FBCHU25		8FBCHU28		8FBCHU30		8FBCHU32	
A	Maximum Fork Height (top of forks)	in (mm)		131.5 (3340)		131.5 (3340)		131.5 (3345)		131.5 (3345)	
B	Free-Lift (top of forks)	in (mm)		6.1 (155)		6.1 (155)		5.3 (135)		5.3 (135)	
C	Fork Size (T x W x L)	in (mm)		1.6 x 5 x 42 (40 x 125 x 1070)		1.6 x 5 x 42 (40 x 125 x 1070)		1.8 x 5 x 42 / (45 x 125 x 1070)		1.8 x 5 x 42 / (45 x 125 x 1070)	
D	Tilt Range (forward / backward)	deg		6 / 8		6 / 8		6 / 8		6 / 8	
E	Length to Fork Face	in (mm)		85.4 (2170)		87.6 (2225)		89.6 (2275)		91.3 (2320)	
F	Overall Width	in (mm)		41.9 (1065)		43.7 (1110)		43.7 (1110)		43.7 (1110)	
G	Mast Lowered Height	in (mm)		83.3 (2110)		83.1 (2110)		83.1 (2110)		83.1 (2110)	
H	Mast Extended Height (top of load backrest)	in (mm)		179.5 (4560)		179.7 (4565)		179.1 (4565)		179.7 (4565)	
I	Overhead Guard Height	in (mm)		88 (2235)		88 (2235)		88 (2235)		88 (2235)	
J	Turning Radius (inside / outside)	in (mm)		76.4 (1940)		72.6 (1845)		77.2 (1960)		78.7 (2000)	
K	Load Distance ¹	in (mm)		16.7 (425)		17.7 (450)		17.7 (450)		17.7 (450)	
L	Basic Right-Angle Stacking Aisle Width ²	in (mm)		93.1 (2365)		90.3 (2295)		94.9 (2410)		96.4 (2450)	
PERFORMANCE DATA				8FBCHU25		8FBCHU28		8FBCHU30		8FBCHU32	
				36V	48V	36V	48V	36V	48V	36V	48V
Speeds ³	Maximum Travel (fwd. / rev.)	Full Load	mph (km/h)	9.6 (15.5)	11.5 (18.5)	9.3 (15)	11.5 (18.5)	9.0 (14.5)	11.2 (18)	9.0 (14.5)	11.2 (18)
		No Load	mph (km/h)	10.9 (17.5)	11.5 (18.5)	10.9 (17.5)	11.5 (18.5)	10.6 (17.0)	11.5 (18.5)	10.6 (17)	11.5 (18.5)
	Lifting	Full Load	fpm (mm/sec)	59 (300)	79 (400)	55 (280)	73 (370)	51 (260)	69 (350)	47 (240)	65 (330)
		No Load	fpm (mm/sec)	106 (540)	130 (660)	91 (460)	116 (590)	91 (460)	116 (590)	91 (460)	116 (590)
Lowering	Full Load	fpm (mm/sec)	98 (500)		98 (500)		98 (500)		98 (500)		
	No Load	fpm (mm/sec)	98 (500)		98 (500)		98 (500)		98 (500)		
Drawbar Pull	Full Load / No Load	3-Min. Rating	lb (kg)	3290 (1490) / 2550 (1160)		3170 (1440) / 2110 (960)		3160 (1430) / 2350 (1070)		3160 (1430) / 2270 (1030)	
		3-Min. Rating	lb (kg)	3290 (1490) / 2550 (1160)		3170 (1440) / 2110 (960)		3160 (1430) / 2350 (1070)		3160 (1430) / 2270 (1030)	
		60-Min. Rating	lb (kg)	1580 (720) / 1690 (760)		1510 (690) / 1650 (750)		1460 (660) / 1630 (740)		1460 (660) / 1630 (740)	
Gradeability*	Full Load / No Load	3-Min. Rating	%	21 / 24		17 / 20		17 / 20		17 / 19	
		3-Min. Rating	%	21 / 24		17 / 20		17 / 20		17 / 19	
		60-Min. Rating	%	9 / 17		7 / 4		7 / 14		7 / 13	
TRUCK WEIGHTS				8FBCHU25		8FBCHU28		8FBCHU30		8FBCHU32	
Total Weight		lb (kg)		6310 (2860)		8060 (3655)		7700 (3490)		8130 (3685)	
Weight Distribution ⁴	Full Load (front / rear)	lb (kg)		12530 (5900) / 1780 (820)		13740 (6460) / 2230 (1030)		14650 (6900) / 2050 (950)		15420 (7180) / 2210 (1060)	
	No Load (front / rear)	lb (kg)		3830 (1735) / 5480 (2485)		3740 (1695) / 6730 (3050)		4080 (1850) / 6620 (3000)		3960 (1795) / 7170 (3250)	
TIRES				8FBCHU25		8FBCHU28		8FBCHU30		8FBCHU32	
Tires	Number (front / rear)			2 / 2		2 / 2		2 / 2		2 / 2	
	Size front / rear			21 x 7 x 15 / 16 x 5 x 10.5		21 x 7 x 15 / 16 x 5 x 10.5		21 x 8 x 15 / 16 x 6 x 10.5		21 x 7 x 15 / 16 x 5 x 10.5	
Wheelbase		in (mm)		54.7 (1390)		51 (1295)		54.7 (1390)		54.7 (1390)	
Tread Width (front / rear)		in (mm)		35 (890) / 36 (915)		35.8 (910) / 36 (915)		35.8 (910) / 36 (915)		35.8 (910) / 36 (915)	
Underclearance (full load)	Minimum <Mast>	in (mm)		3.0 (75)		2.8 (70)		2.8 (70)		2.8 (70)	
	Center of Wheelbase	in (mm)		3.9 (100)		3.9 (100)		3.9 (100)		3.9 (100)	
Brake	Service (foot) / Parking Brake			Hydraulic / Foot		Hydraulic / Foot		Hydraulic / Foot		Hydraulic / Foot	
POWER SYSTEM				8FBCHU25		8FBCHU28		8FBCHU30		8FBCHU32	
				36V	48V	36V	48V	36V	48V	36V	48V
Battery	Voltage / Capacity (STD)	V / Ah		36 / 1190	48 / 850	36 / 1020	48 / 765	36 / 1190	48 / 850	36 / 1190	48 / 850
	6-Hour Rating (high)	V / Ah		36 / 1540	48 / 1100	36 / 1320	48 / 990	36 / 1540	48 / 1100	36 / 1540	48 / 1100
Electric Motors	Drive	kW		10.8	14.8	13.2	18	13.2	18	13.2	18
	Load Handling	kW		11.3	15.1	11.3	15.1	11.3	15.1	11.3	15.1
	Power Steering										
Control Type	Drive			Transistor Inverter		Transistor Inverter		Transistor Inverter		Transistor Inverter	
	Load Handling			Transistor Inverter		Transistor Inverter		Transistor Inverter		Transistor Inverter	
	Power Steering			Transistor Inverter		Transistor Inverter		Transistor Inverter		Transistor Inverter	
Auxiliary Hydraulic Function Specifications (for attachments) ⁵	Max Operating Pressure	psi (kg/cm ²)		2580 (181)		2580 (181)		2580 (181)		2580 (181)	
	Max Flow Rate	gpm (lpm)		11.04		11.04		11.04		11.04	
Reference Page I-A-29 For Flow & Pressure Specifications Chart											

* Computed values.

1 At centerline of front axle to front face of forks.
2 Add load length & clearance.

3 Values indicated reflect speed in H mode. Reference page I-A-29 for S & P mode travel speeds (loaded & unloaded).
4 With standard battery.

5 Values taken at Hydraulic Control Valve. Does not take in to consideration losses through mast plumbing (hosing, fittings, QDs, etc.).

EXTERIOR DIMENSIONS

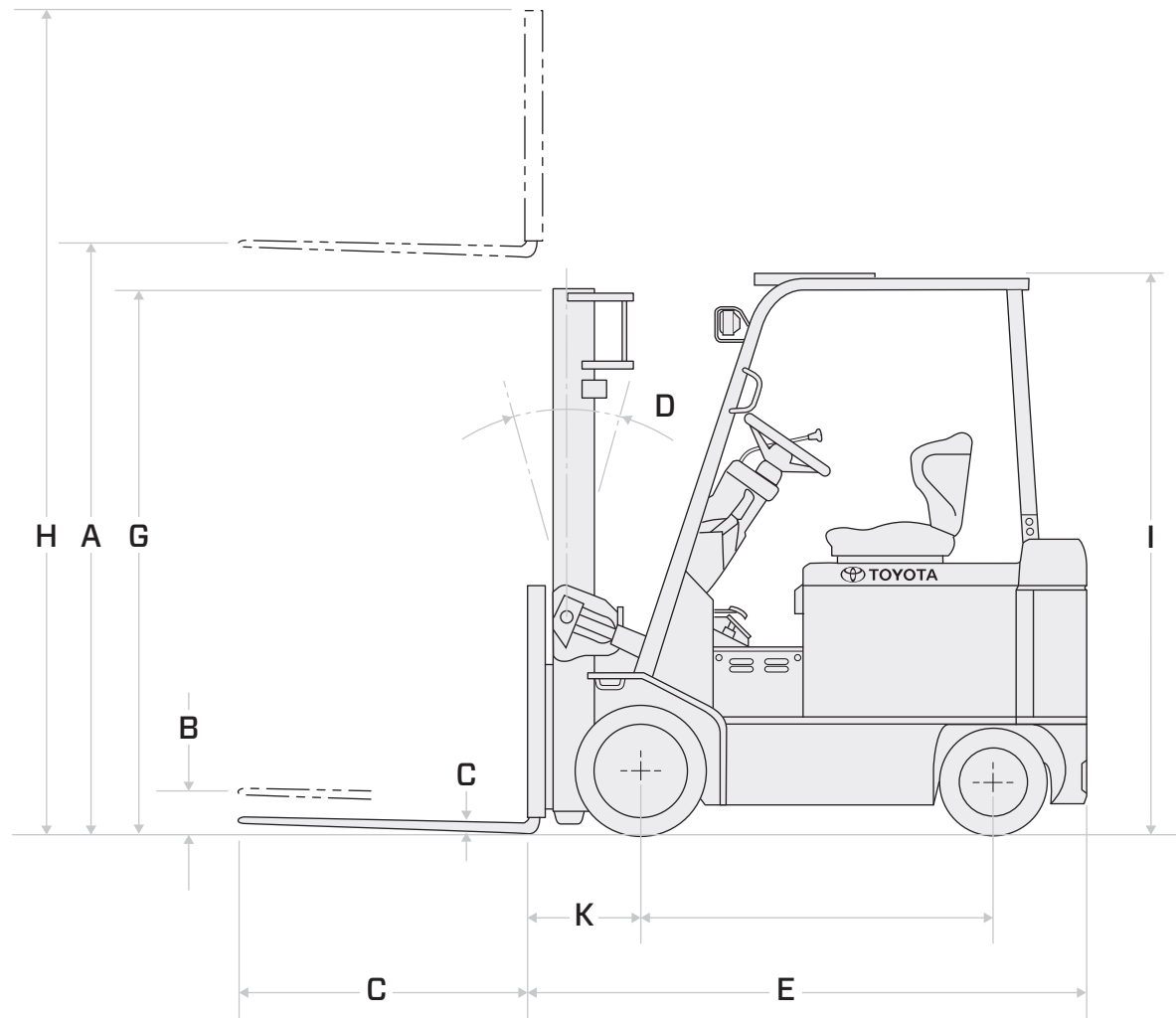
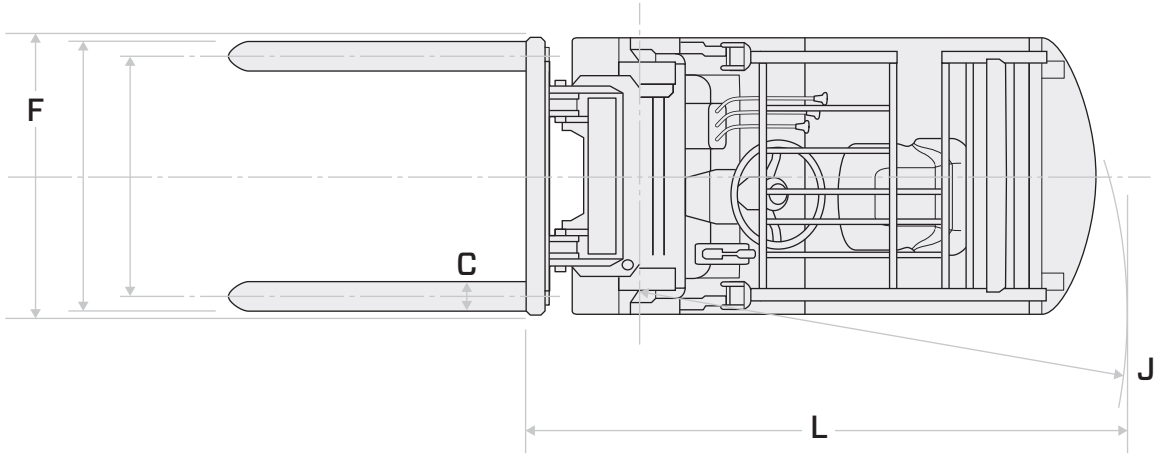

MAST SPECIFICATIONS

MAST TYPE	MAXIMUM FORK HEIGHT (TOP OF FORKS)	OVERALL HEIGHT				FREE-LIFT		SINGLE TIRE			
		LOWERED	EXTENDED		WITHOUT LOAD BACKREST	WITH STANDARD LOAD BACKREST ¹	TILT RANGE		LOAD CAPACITY AT 24 IN. (610 MM) LOAD CENTER		
			WITHOUT LOAD BACKREST	WITH STANDARD LOAD BACKREST ¹			FWD	BWD	NARROW TREAD	WIDE TREAD	
in (mm)		in (mm)	in (mm)	in (mm)	in (mm)	in (mm)	deg	deg	lb (kg)	lb (kg)	
7FBCU15											
Wide Visible (V)	80 (2035)	57.5 (1460)	101.2 (2570)	128.1 (3255)	5.7 (145)	5.7 (145)	6	5	3000 (1340)	3000 (1340)	
	99.5 (2535)	67.3 (1710)	120.9 (3070)	147.8 (3755)	5.7 (145)	5.7 (145)	6	10	3000 (1340)	3000 (1340)	
	107.5 (2735)	71.3 (1810)	128.7 (3270)	155.7 (3955)	5.7 (145)	5.7 (145)	6	10	3000 (1340)	3000 (1340)	
	119 (3035)	77.2 (1960)	140.6 (3570)	167.5 (4255)	5.7 (145)	5.7 (145)	6	10	3000 (1340)	3000 (1340)	
	131 (3335)	83.1 (2110)	152.4 (3870)	179.3 (4555)	5.7 (145)	5.7 (145)	6	10	3000 (1340)	3000 (1340)	
	139 (3535)	87 (2210)	164.2 (4170)	187.2 (4755)	5.7 (145)	5.7 (145)	6	10	3000 (1340)	3000 (1340)	
	147 (3735)	93.3 (2370)	168.1 (4270)	195.1 (4955)	5.7 (145)	5.7 (145)	6	10	3000 (1340)	3000 (1340)	
	158.5 (4035)	100.8 (2560)	179.9 (4570)	206.9 (5255)	5.7 (145)	5.7 (145)	6	10	3000 (1340)	3000 (1340)	
	178.5 (4535)	110.6 (2810)	199.6 (5070)	226.6 (5755)	5.7 (145)	5.7 (145)	6	5	2900 (1300)	2900 (1300)	
Full Free-Lift 2-Stage (FV)	80 (2035)	57.5 (1460)	99.4 (2525)	128.1 (3255)	36.8 (935)	9.5 (240)	6	5	3000 (1340)	3000 (1340)	
	99.5 (2535)	67.3 (1710)	119.1 (3025)	147.8 (3755)	46.7 (1185)	19.3 (490)	6	10	3000 (1340)	3000 (1340)	
	107.5 (2735)	71.3 (1810)	127 (3225)	155.7 (3955)	50.6 (1285)	23.3 (590)	6	10	3000 (1340)	3000 (1340)	
	119 (3035)	77.2 (1960)	138.8 (3525)	167.5 (4255)	56.5 (1435)	29.2 (740)	6	10	3000 (1340)	3000 (1340)	
	131 (3335)	83.1 (2110)	150.6 (3825)	179.3 (4555)	62.4 (1585)	35.1 (890)	6	10	3000 (1340)	3000 (1340)	
	139 (3535)	87 (2210)	158.5 (4025)	187.2 (4755)	66.4 (1685)	39 (990)	6	10	3000 (1340)	3000 (1340)	
	147 (3735)	93.3 (2370)	166.3 (4225)	195.1 (4955)	72.6 (1845)	45.3 (1150)	6	10	3000 (1340)	3000 (1340)	
	158.5 (4035)	100.8 (2560)	178.1 (4525)	206.9 (5255)	80.1 (2035)	52.8 (1340)	6	10	3000 (1340)	3000 (1340)	
	Full Free-Lift 3-Stage (FSV)	147 (3735)	69.3 (1760)	167.9 (4265)	195.1 (4955)	47 (1195)	21.3 (540)	6	5	3000 (1340)	3000 (1340)
158.5 (4035)		73.2 (1860)	179.7 (4565)	206.9 (5255)	51 (1295)	25.2 (640)	6	5	3000 (1340)	3000 (1340)	
170.5 (4335)		77.2 (1960)	191.5 (4865)	218.7 (5555)	54.9 (1395)	29.2 (740)	6	5	2900 (1300)	2900 (1300)	
189 (4800)		83.1 (2110)	209.4 (5320)	237 (6020)	60.8 (1545)	35.1 (890)	6	5	2800 (1250)	2800 (1250)	
198 (5035)		87 (2210)	219.1 (5565)	246.3 (6255)	64.8 (1645)	39 (990)	6	5	2750 (1230)	2750 (1230)	
217.5 (5535)		93.3 (2370)	238.8 (6065)	265.9 (6755)	71.1 (1805)	45.3 (1150)	6	5	2200 (990) ²	2650 (1190) ³	
237.5 (6035)		100.8 (2560)	258.5 (6565)	285.6 (7255)	78.5 (1995)	52.8 (1340)	6	5	1540 (670) ²	2200 (810) ³	

MAST TYPE	MAXIMUM FORK HEIGHT (TOP OF FORKS)	OVERALL HEIGHT				FREE-LIFT		SINGLE TIRE			
		LOWERED	EXTENDED		WITHOUT LOAD BACKREST	WITH STANDARD LOAD BACKREST ¹	TILT RANGE		LOAD CAPACITY AT 24 IN. (610 MM) LOAD CENTER		
			WITHOUT LOAD BACKREST	WITH STANDARD LOAD BACKREST ¹			FWD	BWD	NARROW TREAD	WIDE TREAD	
in (mm)		in (mm)	in (mm)	in (mm)	in (mm)	in (mm)	deg	deg	lb (kg)	lb (kg)	
7FBCU18											
Wide Visible (V)	80 (2035)	57.5 (1460)	101.2 (2570)	128.1 (3255)	5.7 (145)	5.7 (145)	6	5	3500 (1570)	N/A	
	99.5 (2535)	67.3 (1710)	120.9 (3070)	147.8 (3755)	5.7 (145)	5.7 (145)	6	10	3500 (1570)	N/A	
	107.5 (2735)	71.3 (1810)	128.7 (3270)	155.7 (3955)	5.7 (145)	5.7 (145)	6	10	3500 (1570)	N/A	
	119 (3035)	77.2 (1960)	140.6 (3570)	167.5 (4255)	5.7 (145)	5.7 (145)	6	10	3500 (1570)	N/A	
	131 (3335)	83.1 (2110)	152.4 (3870)	179.3 (4555)	5.7 (145)	5.7 (145)	6	10	3500 (1570)	N/A	
	139 (3535)	87 (2210)	164.2 (4170)	187.2 (4755)	5.7 (145)	5.7 (145)	6	10	3500 (1570)	N/A	
	147 (3735)	93.3 (2370)	168.1 (4270)	195.1 (4955)	5.7 (145)	5.7 (145)	6	10	3500 (1570)	N/A	
	158.5 (4035)	100.8 (2560)	179.9 (4570)	206.9 (5255)	5.7 (145)	5.7 (145)	6	10	3500 (1570)	N/A	
	178.5 (4535)	110.6 (2810)	199.6 (5070)	226.6 (5755)	5.7 (145)	5.7 (145)	6	5	3300 (1480)	N/A	
Full Free-Lift 2-Stage (FV)	80 (2035)	57.5 (1460)	99.4 (2525)	128.1 (3255)	36.8 (935)	9.5 (240)	6	5	3500 (1570)	N/A	
	99.5 (2535)	67.3 (1710)	119.1 (3025)	147.8 (3755)	46.7 (1185)	19.3 (490)	6	10	3500 (1570)	N/A	
	107.5 (2735)	71.3 (1810)	127 (3225)	155.7 (3955)	50.6 (1285)	23.3 (590)	6	10	3500 (1570)	N/A	
	119 (3035)	77.2 (1960)	138.8 (3525)	167.5 (4255)	56.5 (1435)	29.2 (740)	6	10	3500 (1570)	N/A	
	131 (3335)	83.1 (2110)	150.6 (3825)	179.3 (4555)	62.4 (1585)	35.1 (890)	6	10	3500 (1570)	N/A	
	139 (3535)	87 (2210)	158.5 (4025)	187.2 (4755)	66.4 (1685)	39 (990)	6	10	3500 (1570)	N/A	
	147 (3735)	93.3 (2370)	166.3 (4225)	195.1 (4955)	72.6 (1845)	45.3 (1150)	6	10	3500 (1570)	N/A	
	158.5 (4035)	100.8 (2560)	178.1 (4525)	206.9 (5255)	80.1 (2035)	52.8 (1340)	6	10	3500 (1570)	N/A	
	Full Free-Lift 3-Stage (FSV)	147 (3735)	69.3 (1760)	167.9 (4265)	195.1 (4955)	47 (1195)	21.3 (540)	6	5	3500 (1570)	N/A
158.5 (4035)		73.2 (1860)	179.7 (4565)	206.9 (5255)	51 (1295)	25.2 (640)	6	5	3500 (1570)	N/A	
170.5 (4335)		77.2 (1960)	191.5 (4865)	218.7 (5555)	54.9 (1395)	29.2 (740)	6	5	3400 (1570)	N/A	
189 (4800)		83.1 (2110)	209.4 (5320)	237 (6020)	60.8 (1545)	35.1 (890)	6	5	3090 (1410)	N/A	
198 (5035)		87 (2210)	219.1 (5565)	246.3 (6255)	64.8 (1645)	39 (990)	6	5	3050 (1350)	N/A	
217.5 (5535)		93.3 (2370)	238.8 (6065)	265.9 (6755)	71.1 (1805)	45.3 (1150)	6	5	2800 (1150)	N/A	
237.5 (6035)		100.8 (2560)	258.5 (6565)	285.6 (7255)	78.5 (1995)	52.8 (1340)	6	5	1700 (750)	N/A	

1 Height of standard load backrest is 48" (1220 mm).
 2 Available as a TSDR only & subject to TIEM review.
 3 Requires option G00G Wide Tread/Wide Tire.

MAST TYPE	MAXIMUM FORK HEIGHT (TOP OF FORKS)	OVERALL HEIGHT				FREE-LIFT		TILT RANGE		LOAD CAPACITY AT 24 IN. (610 MM) LOAD CENTER	
		LOWERED	EXTENDED		WITHOUT LOAD BACKREST	WITH STANDARD LOAD BACKREST ¹	FWD	BWD	STANDARD TREAD	WIDE TREAD	
			WITHOUT LOAD BACKREST	WITH STANDARD LOAD BACKREST ¹							
			in (mm)	in (mm)							in (mm)
8FBCU20											
Wide Visible (V)	80 (2040)	57.7 (1465)	105.9 (2690)	128.3 (3260)	6.1 (155)	6.1 (155)	6	5	4000 (1810)	4000 (1810)	
	119.5 (3040)	77.4 (1965)	145.2 (3690)	167.7 (4260)	6.1 (155)	6.1 (155)	6	8	4000 (1810)	4000 (1810)	
	131.5 (3340)	83.3 (2115)	157.1 (3990)	179.5 (4560)	6.1 (155)	6.1 (155)	6	8	4000 (1810)	4000 (1810)	
	139 (3540)	87.2 (2215)	164.9 (4190)	187.4 (4760)	6.1 (155)	6.1 (155)	6	8	4000 (1810)	4000 (1810)	
	147 (3740)	93.5 (2375)	173.8 (4390)	195.3 (4960)	6.1 (155)	6.1 (155)	6	8	4000 (1810)	4000 (1810)	
Full Free-Lift 2-Stage (FV)	159 (4040)	101 (2565)	184.6 (4690)	207.1 (5260)	6.1 (155)	6.1 (155)	6	8	4000 (1810)	4000 (1810)	
	119.5 (3040)	77.4 (1965)	143.5 (3645)	167.7 (4260)	53.6 (1360)	29.3 (745)	6	8	4000 (1810)	4000 (1810)	
	131.5 (3340)	83.3 (2115)	155.3 (3945)	179.5 (4560)	59.5 (1510)	35.2 (895)	6	8	4000 (1810)	4000 (1810)	
Full Free-Lift 3-Stage (FSV)	139 (3540)	87.2 (2215)	163.1 (4145)	187.4 (4760)	63.4 (1610)	39.2 (995)	6	8	4000 (1810)	4000 (1810)	
	159 (4040)	73.4 (1865)	184.2 (4680)	207.1 (5260)	48.1 (1220)	25.4 (645)	6	5	4000 (1810)	4000 (1810)	
	170.5 (4340)	77.4 (1965)	196 (4980)	218.9 (5560)	52 (1320)	29.4 (745)	6	5	4000 (1810)	4000 (1810)	
	189 (4800)	83.3 (2115)	214.3 (5445)	237.2 (6025)	57.9 (1470)	35.3 (895)	6	5	3900 (1770)	3900 (1770)	
	198 (5040)	87.2 (2215)	223.6 (5680)	246.5 (6260)	61.9 (1570)	39.2 (995)	6	5	3850 (1750)	3850 (1750)	
	218 (5540)	93.5 (2375)	243.3 (6180)	266.1 (6760)	68.2 (1150)	45.5 (1155)	6	5	3650 (1660)	3650 (1660)	
Full Free-Lift 4-Stage (QFV)	237.5 (6040)	101 (2565)	263 (6680)	285.8 (7260)	75.6 (1340)	53 (1345)	6	5	—	3500 (1590) ²	
	241.5 (6100)	83.1 (2110)	262.6 (6670)	289.6 (7355)	62.1 (1575)	35 (890)	6	5	—	3700 (1680) ²	
	259.5 (6600)	89 (2260)	280.7 (7130)	307.7 (7815)	68 (1725)	40.9 (1040)	6	5	—	3200 (1450) ²	
	278 (700)	95.3 (2420)	298.8 (7590)	325.8 (8275)	74.3 (1885)	47.2 (1200)	6	5	—	1900 (860) ²	

MAST TYPE	MAXIMUM FORK HEIGHT (TOP OF FORKS)	OVERALL HEIGHT				FREE-LIFT		TILT RANGE		LOAD CAPACITY AT 24 IN. (610 MM) LOAD CENTER	
		LOWERED	EXTENDED		WITHOUT LOAD BACKREST	WITH STANDARD LOAD BACKREST ¹	FWD	BWD	STANDARD TREAD	WIDE TREAD	
			WITHOUT LOAD BACKREST	WITH STANDARD LOAD BACKREST ¹							
			in (mm)	in (mm)							in (mm)
8FBCU20-COMP											
Wide Visible (V)	80 (2040)	57.7 (1465)	105.9 (2690)	128.3 (3260)	6.1 (155)	6.1 (155)	6	5	4000 (1810)	4000 (1810)	
	119.5 (3040)	77.4 (1965)	145.2 (3690)	167.7 (4260)	6.1 (155)	6.1 (155)	6	8	4000 (1810)	4000 (1810)	
	131.5 (3340)	83.3 (2115)	157.1 (3990)	179.5 (4560)	6.1 (155)	6.1 (155)	6	8	4000 (1810)	4000 (1810)	
	139 (3540)	87.2 (2215)	164.9 (4190)	187.4 (4760)	6.1 (155)	6.1 (155)	6	8	4000 (1810)	4000 (1810)	
	147 (3740)	93.5 (2375)	173.8 (4390)	195.3 (4960)	6.1 (155)	6.1 (155)	6	8	4000 (1810)	4000 (1810)	
Full Free-Lift 2-Stage (FV)	159 (4040)	101 (2565)	184.6 (4690)	207.1 (5260)	6.1 (155)	6.1 (155)	6	8	4000 (1810)	4000 (1810)	
	119.5 (3040)	77.4 (1965)	143.5 (3645)	167.7 (4260)	53.6 (1360)	29.3 (745)	6	8	4000 (1810)	4000 (1810)	
	131.5 (3340)	83.3 (2115)	155.3 (3945)	179.5 (4560)	59.5 (1510)	35.2 (895)	6	8	4000 (1810)	4000 (1810)	
Full Free-Lift 3-Stage (FSV)	139 (3540)	87.2 (2215)	163.1 (4145)	187.4 (4760)	63.4 (1610)	39.2 (995)	6	8	4000 (1810)	4000 (1810)	
	159 (4040)	73.4 (1865)	184.2 (4680)	207.1 (5260)	48.1 (1220)	25.4 (645)	6	5	4000 (1810)	4000 (1810)	
	170.5 (4340)	77.4 (1965)	196 (4980)	218.9 (5560)	52 (1320)	29.4 (745)	6	5	4000 (1810)	4000 (1810)	
	189 (4800)	83.3 (2115)	214.3 (5445)	237.2 (6025)	57.9 (1470)	35.3 (895)	6	5	3900 (1770)	3900 (1770)	
	198 (5040)	87.2 (2215)	223.6 (5680)	246.5 (6260)	61.9 (1570)	39.2 (995)	6	5	3850 (1750)	3850 (1750)	
	218 (5540)	93.5 (2375)	243.3 (6180)	266.1 (6760)	68.2 (1150)	45.5 (1155)	6	5	3650 (1660)	3650 (1660)	
Full Free-Lift 4-Stage (QFV)	237.5 (6040)	101 (2565)	263 (6680)	285.8 (7260)	75.6 (1340)	53 (1345)	6	5	-	3500 (1590) ²	
	241.5 (6100)	83.1 (2110)	262.6 (6670)	289.6 (7355)	62.1 (1575)	35 (890)	6	5	-	3550 (1610) ²	
	259.5 (6600)	89 (2260)	280.7 (7130)	307.7 (7815)	68 (1725)	40.9 (1040)	6	5	-	3200 (1440) ²	
	278 (700)	95.3 (2420)	298.8 (7590)	325.8 (8275)	74.3 (1885)	47.2 (1200)	6	5	-	1900 (860) ²	

¹ Height of standard load backrest is 48" (1220 mm).

² Requires option G00A Wide Tread.

MAST SPECIFICATIONS

MAST TYPE	MAXIMUM FORK HEIGHT (TOP OF FORKS)	OVERALL HEIGHT				FREE-LIFT		TILT RANGE		LOAD CAPACITY AT 24 IN. (610 MM) LOAD CENTER	
		LOWERED	EXTENDED		WITHOUT LOAD BACKREST	WITH STANDARD LOAD BACKREST ¹	FWD	BWD	STANDARD TREAD	WIDE TREAD	
			WITHOUT LOAD BACKREST	WITH STANDARD LOAD BACKREST ¹							
	in (mm)	in (mm)	in (mm)	in (mm)	in (mm)	in (mm)	deg	deg	lb (kg)	lb (kg)	
8FBCU25											
Wide Visible (V)	80.5 (2040)	57.7 (1465)	105.9 (2690)	128.3 (3260)	6.1 (155)	6.1 (155)	6	5	5000 (2270)	5000 (2270)	
	119.5 (3040)	77.4 (1965)	145.2 (3690)	167.7 (4260)	6.1 (155)	6.1 (155)	6	8	5000 (2270)	5000 (2270)	
	131.5 (3340)	83.3 (2115)	157.1 (3990)	179.5 (4560)	6.1 (155)	6.1 (155)	6	8	5000 (2270)	5000 (2270)	
	139.0 (3540)	87.2 (2215)	164.9 (4190)	187.4 (4760)	6.1 (155)	6.1 (155)	6	8	5000 (2270)	5000 (2270)	
	147 (3740)	93.5 (2375)	173.8 (4390)	195.3 (4960)	6.1 (155)	6.1 (155)	6	8	5000 (2270)	5000 (2270)	
Full Free-Lift 2-Stage (FV)	159 (4040)	101 (2565)	184.6 (4690)	207.1 (5260)	6.1 (155)	6.1 (155)	6	8	5000 (2270)	5000 (2270)	
	119.5 (3040)	77.4 (1965)	143.5 (3645)	167.7 (4260)	53.6 (1360)	29.3 (745)	6	8	5000 (2270)	5000 (2270)	
Full Free-Lift 3-Stage (FSV)	131.5 (3340)	83.3 (2115)	155.3 (3945)	179.5 (4560)	59.5 (1510)	35.2 (895)	6	8	5000 (2270)	5000 (2270)	
	139 (3540)	87.2 (2215)	163.1 (4145)	187.4 (4760)	63.4 (1610)	39.2 (995)	6	8	5000 (2270)	5000 (2270)	
	159 (4040)	73.4 (1865)	184.2 (4680)	207.1 (5260)	48.1 (1220)	25.4 (645)	6	5	5000 (2270)	5000 (2270)	
	170.5 (4340)	77.4 (1965)	196 (4980)	218.9 (5560)	52 (1320)	29.4 (745)	6	5	5000 (2270)	5000 (2270)	
	189 (4800)	83.3 (2115)	214.3 (5445)	237.2 (6025)	57.9 (1470)	35.3 (895)	6	5	4850 (2200)	4850 (2200)	
Full Free-Lift 4-Stage (QFV)	198 (5040)	87.2 (2215)	223.6 (5680)	246.5 (6260)	61.9 (1570)	39.2 (995)	6	5	4750 (2150)	4750 (2150)	
	218 (5540)	93.5 (2375)	243.3 (6180)	266.1 (6760)	68.2 (1150)	45.5 (1155)	6	5	—	4600 (2090) ²	
	237.5 (6040)	101 (2565)	263 (6680)	285.8 (7260)	75.6 (1340)	53 (1345)	6	5	—	4000 (1810) ²	
Full Free-Lift 4-Stage (QFV)	241.5 (6100)	83.1 (2110)	262.6 (6670)	289.6 (7355)	62.1 (1575)	35 (890)	6	5	—	4400 (2000) ³	
	259.5 (6600)	89 (2260)	280.7 (7130)	307.7 (7815)	68 (1725)	40.9 (1040)	6	5	—	3850 (1750) ³	
	278 (700)	95.3 (2420)	298.8 (7590)	325.8 (8275)	74.3 (1885)	47.2 (1200)	6	5	—	2500 (1130) ³	

MAST TYPE	MAXIMUM FORK HEIGHT (TOP OF FORKS)	OVERALL HEIGHT				FREE-LIFT		TILT RANGE		LOAD CAPACITY AT 24 IN. (610 MM) LOAD CENTER	
		LOWERED	EXTENDED		WITHOUT LOAD BACKREST	WITH STANDARD LOAD BACKREST ¹	FWD	BWD	STANDARD TREAD	WIDE TREAD	
			WITHOUT LOAD BACKREST	WITH STANDARD LOAD BACKREST ¹							
	in (mm)	in (mm)	in (mm)	in (mm)	in (mm)	in (mm)	deg	deg	lb (kg)	lb (kg)	
8FBCU25-COMP											
Wide Visible (V)	80.5 (2040)	57.7 (1465)	105.9 (2690)	128.3 (3260)	6.1 (155)	6.1 (155)	6	5	5000 (2270)	5000 (2270)	
	119.5 (3040)	77.4 (1965)	145.2 (3690)	167.7 (4260)	6.1 (155)	6.1 (155)	6	8	5000 (2270)	5000 (2270)	
	131.5 (3340)	83.3 (2115)	157.1 (3990)	179.5 (4560)	6.1 (155)	6.1 (155)	6	8	5000 (2270)	5000 (2270)	
	139.0 (3540)	87.2 (2215)	164.9 (4190)	187.4 (4760)	6.1 (155)	6.1 (155)	6	8	5000 (2270)	5000 (2270)	
	147 (3740)	93.5 (2375)	173.8 (4390)	195.3 (4960)	6.1 (155)	6.1 (155)	6	8	5000 (2270)	5000 (2270)	
Full Free-Lift 2-Stage (FV)	159 (4040)	101 (2565)	184.6 (4690)	207.1 (5260)	6.1 (155)	6.1 (155)	6	8	5000 (2270)	5000 (2270)	
	119.5 (3040)	77.4 (1965)	143.5 (3645)	167.7 (4260)	53.6 (1360)	29.3 (745)	6	8	5000 (2270)	5000 (2270)	
Full Free-Lift 3-Stage (FSV)	131.5 (3340)	83.3 (2115)	155.3 (3945)	179.5 (4560)	59.5 (1510)	35.2 (895)	6	8	5000 (2270)	5000 (2270)	
	139 (3540)	87.2 (2215)	163.1 (4145)	187.4 (4760)	63.4 (1610)	39.2 (995)	6	8	5000 (2270)	5000 (2270)	
	159 (4040)	73.4 (1865)	184.2 (4680)	207.1 (5260)	48.1 (1220)	25.4 (645)	6	5	5000 (2270)	5000 (2270)	
	170.5 (4340)	77.4 (1965)	196 (4980)	218.9 (5560)	52 (1320)	29.4 (745)	6	5	5000 (2270)	5000 (2270)	
	189 (4800)	83.3 (2115)	214.3 (5445)	237.2 (6025)	57.9 (1470)	35.3 (895)	6	5	4850 (2200)	4850 (2200)	
Full Free-Lift 4-Stage (QFV)	198 (5040)	87.2 (2215)	223.6 (5680)	246.5 (6260)	61.9 (1570)	39.2 (995)	6	5	4750 (2150)	4750 (2150)	
	218 (5540)	93.5 (2375)	243.3 (6180)	266.1 (6760)	68.2 (1150)	45.5 (1155)	6	5	—	4550 (2060) ²	
	237.5 (6040)	101 (2565)	263 (6680)	285.8 (7260)	75.6 (1340)	53 (1345)	6	5	—	4400 (2000) ²	
Full Free-Lift 4-Stage (QFV)	241.5 (6100)	83.1 (2110)	262.6 (6670)	289.6 (7355)	62.1 (1575)	35 (890)	6	5	—	4200 (1900) ²	
	259.5 (6600)	89 (2260)	280.7 (7130)	307.7 (7815)	68 (1725)	40.9 (1040)	6	5	—	3950 (1790) ²	
	278 (700)	95.3 (2420)	298.8 (7590)	325.8 (8275)	74.3 (1885)	47.2 (1200)	6	5	—	2700 (1220) ²	

¹ Height of standard load backrest is 48" (1220 mm).
² Requires option G00A Wide Tread.

MAST TYPE	MAXIMUM FORK HEIGHT (TOP OF FORKS)	OVERALL HEIGHT				FREE-LIFT		TILT RANGE		LOAD CAPACITY AT 24 IN. (610 MM) LOAD CENTER	
		LOWERED	EXTENDED		WITHOUT LOAD BACKREST	WITH STANDARD LOAD BACKREST ¹	FWD	BWD	STANDARD TREAD	WIDE TREAD	
			WITHOUT LOAD BACKREST	WITH STANDARD LOAD BACKREST ¹							
			in (mm)	in (mm)							
8FBCHU25											
Wide Visible (V)	80.0 (2040)	57.7 (1465)	105.9 (2690)	128.3 (3260)	6.1 (155)	6.1 (155)	6	5	5000 (2270)	5000 (2270)	
	119.5 (3040)	77.4 (1965)	145.2 (3690)	167.7 (4260)	6.1 (155)	6.1 (155)	6	8	5000 (2270)	5000 (2270)	
	131.5 (3340)	83.3 (2115)	157.1 (3990)	179.5 (4560)	6.1 (155)	6.1 (155)	6	8	5000 (2270)	5000 (2270)	
	139.0 (3540)	87.2 (2215)	164.9 (4190)	187.4 (4760)	6.1 (155)	6.1 (155)	6	8	5000 (2270)	5000 (2270)	
	147 (3740)	93.5 (2375)	173.8 (4390)	195.3 (4960)	6.1 (155)	6.1 (155)	6	8	5000 (2270)	5000 (2270)	
Full Free-Lift 2-Stage (FV)	159 (4040)	101 (2565)	184.6 (4690)	207.1 (5260)	6.1 (155)	6.1 (155)	6	8	5000 (2270)	5000 (2270)	
	119.5 (3040)	77.4 (1965)	143.5 (3645)	167.7 (4260)	53.6 (1360)	29.3 (745)	6	8	5000 (2270)	5000 (2270)	
	131.5 (3340)	83.3 (2115)	155.3 (3945)	179.5 (4560)	59.5 (1510)	35.2 (895)	6	8	5000 (2270)	5000 (2270)	
Full Free-Lift 3-Stage (FSV)	139 (3540)	87.2 (2215)	163.1 (4145)	187.4 (4760)	63.4 (1610)	39.2 (995)	6	8	5000 (2270)	5000 (2270)	
	159 (4040)	73.4 (1865)	184.2 (4680)	207.1 (5260)	48.1 (1220)	25.4 (645)	6	5	5000 (2270)	5000 (2270)	
	170.5 (4340)	77.4 (1965)	196 (4980)	218.9 (5560)	52 (1320)	29.4 (745)	6	5	5000 (2270)	5000 (2270)	
	189 (4800)	83.3 (2115)	214.3 (5445)	237.2 (6025)	57.9 (1470)	35.3 (895)	6	5	4850 (2200)	4850 (2200)	
	198 (5040)	87.2 (2215)	223.6 (5680)	246.5 (6260)	61.9 (1570)	39.2 (995)	6	5	4750 (2150)	4750 (2150)	
Full Free-Lift 4-Stage (QFV)	218 (5540)	93.5 (2375)	243.3 (6180)	266.1 (6760)	68.2 (1150)	45.5 (1155)	6	5	—	4600 (2090) ²	
	237.5 (6040)	101 (2565)	263 (6680)	285.8 (7260)	75.6 (1340)	53 (1345)	6	5	—	4150 (1880) ²	
	241.5 (6100)	83.1 (2110)	262.6 (6670)	289.6 (7355)	62.1 (1575)	35 (890)	6	5	—	4250 (1930) ²	
	259.5 (6600)	89 (2260)	280.7 (7130)	307.7 (7815)	68 (1725)	40.9 (1040)	6	5	—	4000 (1810) ²	
	278 (700)	95.3 (2420)	298.8 (7590)	325.8 (8275)	74.3 (1885)	47.2 (1200)	6	5	—	2850 (1290) ²	

MAST TYPE	MAXIMUM FORK HEIGHT (TOP OF FORKS)	OVERALL HEIGHT				FREE-LIFT		TILT RANGE		LOAD CAPACITY AT 24 IN. (610 MM) LOAD CENTER	
		LOWERED	EXTENDED		WITHOUT LOAD BACKREST	WITH STANDARD LOAD BACKREST ¹	FWD	BWD	STANDARD TREAD	WIDE TREAD	
			WITHOUT LOAD BACKREST	WITH STANDARD LOAD BACKREST ¹							
			in (mm)	in (mm)							
8FBCHU28											
Wide Visible (V)	80.5 (2045)	57.5 (1460)	107.9 (2740)	128.5 (3265)	5.3 (135)	5.3 (135)	6	5	5500 (2490)	5500 (2490)	
	119.5 (3045)	77.2 (1960)	147.2 (3740)	167.9 (4265)	5.3 (135)	5.3 (135)	6	8	5500 (2490)	5500 (2490)	
	131.5 (3345)	83.1 (2110)	159.1 (4040)	179.7 (4565)	5.3 (135)	5.3 (135)	6	8	5500 (2490)	5500 (2490)	
	139.5 (3545)	87 (2210)	166.9 (4240)	187.6 (4765)	5.3 (135)	5.3 (135)	6	8	5500 (2490)	5500 (2490)	
	147 (3745)	93.3 (2370)	174.8 (4440)	195.5 (4965)	5.3 (135)	5.3 (135)	6	8	5500 (2490)	5500 (2490)	
Full Free-Lift 2-Stage (FV)	159 (4045)	100.8 (2560)	186.6 (4740)	207.3 (5265)	5.3 (135)	5.3 (135)	6	8	5500 (2490)	5500 (2490)	
	119.5 (3045)	77.2 (1960)	143.9 (3655)	167.8 (4265)	53.2 (1350)	29.2 (740)	6	8	5500 (2490)	5500 (2490)	
	131.5 (3345)	83.1 (2110)	155.8 (3955)	179.7 (4565)	59.1 (1500)	35.1 (890)	6	8	5500 (2490)	5500 (2490)	
Full Free-Lift 3-Stage (FSV)	139.5 (3545)	87 (2210)	163.7 (4155)	187.5 (4765)	63.1 (1600)	39.1 (990)	6	8	5500 (2490)	5500 (2490)	
	159 (4045)	77.2 (1960)	183.2 (4655)	207.2 (5265)	53.1 (1349)	50.1 (1273)	6	5	5500 (2490)	5500 (2490)	
	171 (4345)	83.1 (2110)	195 (4955)	219 (5565)	59.1 (1501)	56 (1422)	6	5	5350 (2430)	5350 (2430)	
	187 (4750)	87 (2210)	210.8 (5355)	234.8 (5965)	63 (1660)	59.9 (1521)	6	5	5300 (2400)	5300 (2400)	
	198.5 (5045)	93.3 (2370)	222.6 (5655)	246.6 (6265)	69.3 (1760)	66.2 (1681)	6	5	5250 (2380)	5250 (2380)	
Full Free-Lift 4-Stage (QFV) ³	218 (5545)	100.8 (2560)	242.3 (6155)	266.3 (6765)	76.8 (1951)	73.7 (1872)	6	5	5050 (2290)	5050 (2290)	
	237.5 (6045)	110.5 (2810)	262 (6655)	285.9 (7265)	86.6 (2200)	83.5 (2121)	6	5	4250 (1920)	4850 (2200)	
	241.5 (6100)	83.1 (2110)	262.6 (6670)	289.6 (7355)	62.1 (1575)	35 (890)	6	5	—	4500 (2040) ²	
	259.5 (6600)	89 (2260)	280.7 (7130)	307.7 (7815)	68 (1725)	40.9 (1040)	6	5	—	3200 (1440) ²	
	278 (7000)	95.3 (2420)	298.8 (7590)	325.8 (8275)	74.3 (1885)	47.2 (1200)	6	5	—	1900 (860) ²	

* All capacities of 1500 lbs. or less are subject to a secondary review & could be denied by Toyota.

¹ Height of standard load backrest is 48" (1220 mm).

² Requires option G00A Wide Tread.

³ QFV mast has 36"-wide Class II carriage.

MAST SPECIFICATIONS

MAST TYPE	MAXIMUM FORK HEIGHT (TOP OF FORKS)	OVERALL HEIGHT				FREE-LIFT		TILT RANGE		LOAD CAPACITY AT 24 IN. (610 MM) LOAD CENTER	
		LOWERED	EXTENDED		WITHOUT LOAD BACKREST	WITH STANDARD LOAD BACKREST ¹	FWD	BWD	STANDARD TREAD	WIDE TREAD	
			WITHOUT LOAD BACKREST	WITH STANDARD LOAD BACKREST ¹							
in (mm)		in (mm)	in (mm)	in (mm)	in (mm)	in (mm)	deg	deg	lb (kg)	lb (kg)	
8FBCU30											
Wide Visible (V)	80.5 (2045)	57.5 (1460)	107.9 (2740)	128.5 (3265)	5.3 (135)	5.3 (135)	6	5	6000 (2720)	6000 (2720)	
	119.5 (3045)	77.2 (1960)	147.2 (3740)	167.9 (4265)	5.3 (135)	5.3 (135)	6	8	6000 (2720)	6000 (2720)	
	131.5 (3345)	83.1 (2110)	159.1 (4040)	179.7 (4565)	5.3 (135)	5.3 (135)	6	8	6000 (2720)	6000 (2720)	
	139.5 (3545)	87 (2210)	166.9 (4240)	187.6 (4765)	5.3 (135)	5.3 (135)	6	8	6000 (2720)	6000 (2720)	
	147 (3745)	93.3 (2370)	174.8 (4440)	195.5 (4965)	5.3 (135)	5.3 (135)	6	8	6000 (2720)	6000 (2720)	
Full Free-Lift 2-Stage (FV)	119.5 (3045)	77.2 (1960)	143.9 (3655)	167.8 (4265)	53.2 (1350)	29.2 (740)	6	8	6000 (2720)	6000 (2720)	
	131.5 (3345)	83.1 (2110)	155.7 (3955)	179.7 (4565)	59.1 (1500)	35.1 (890)	6	8	6000 (2720)	6000 (2720)	
	139.5 (3545)	87 (2210)	163.5 (4155)	187.5 (4765)	63.1 (1600)	39.1 (990)	6	8	6000 (2720)	6000 (2720)	
Full Free-Lift 3-Stage (FSV)	159 (4045)	77.2 (1960)	183.2 (4655)	207.2 (5265)	53.1 (1349)	29.2 (745)	6	5	6000 (2720)	6000 (2720)	
	171 (4345)	83.1 (2110)	195 (4955)	219 (5565)	59.1 (1501)	35.1 (890)	6	5	5900 (2680)	5900 (2680)	
	187 (4750)	87 (2210)	210.8 (5355)	234.8 (5965)	63 (1660)	39.1 (990)	6	5	5800 (2630)	5800 (2630)	
	198.5 (5045)	93.3 (2370)	222.6 (5655)	246.6 (6265)	69.3 (1760)	45.4 (1150)	6	5	5650 (2560)	5650 (2560)	
	218 (5545)	100.8 (2560)	242.3 (6155)	266.3 (6765)	76.8 (1951)	52.9 (1340)	6	5	5450 (2470)	5450 (2470)	
Full Free-Lift 4-Stage (QFV) ³	237.5 (6045)	110.6 (2810)	262 (6655)	285.9 (7265)	86.6 (2200)	62.7 (1590)	6	5	4400 (1990)	5250 (2380)	
	241.5 (6100)	83.1 (2110)	262.6 (6670)	289.6 (7355)	62.1 (1575)	35 (890)	6	5	—	4500 (2040) ²	
	259.5 (6600)	89 (2260)	280.7 (7130)	307.7 (7815)	68 (1725)	40.9 (1040)	6	5	—	3450 (1560) ²	
	278 (7000)	95.3 (2420)	298.8 (7590)	325.8 (8275)	74.3 (1885)	47.2 (1200)	6	5	—	2250 (1020) ²	

MAST TYPE	MAXIMUM FORK HEIGHT (TOP OF FORKS)	OVERALL HEIGHT				FREE-LIFT		TILT RANGE		LOAD CAPACITY AT 24 IN. (610 MM) LOAD CENTER	
		LOWERED	EXTENDED		WITHOUT LOAD BACKREST	WITH STANDARD LOAD BACKREST ¹	FWD	BWD	STANDARD TREAD	WIDE TREAD	
			WITHOUT LOAD BACKREST	WITH STANDARD LOAD BACKREST ¹							
in (mm)		in (mm)	in (mm)	in (mm)	in (mm)	in (mm)	deg	deg	lb (kg)	lb (kg)	
8FBCU32											
Wide Visible (V)	80.5 (2045)	57.5 (1460)	107.9 (2740)	128.5 (3265)	5.3 (135)	5.3 (135)	6	5	6500 (2950)	6500 (2950)	
	119.5 (3045)	77.2 (1960)	147.2 (3740)	167.9 (4265)	5.3 (135)	5.3 (135)	6	8	6500 (2950)	6500 (2950)	
	131.5 (3345)	83.1 (2110)	159.1 (4040)	179.7 (4565)	5.3 (135)	5.3 (135)	6	8	6500 (2950)	6500 (2950)	
	139.5 (3545)	87 (2210)	166.9 (4240)	187.6 (4765)	5.3 (135)	5.3 (135)	6	8	6500 (2950)	6500 (2950)	
	147 (3745)	93.3 (2370)	174.8 (4440)	195.5 (4965)	5.3 (135)	5.3 (135)	6	8	6500 (2950)	6500 (2950)	
Full Free-Lift 2-Stage (FV)	119.5 (3045)	77.2 (1960)	147 (3735)	167.8 (4265)	50.1 (1270)	29.2 (740)	6	8	6500 (2950)	6500 (2950)	
	131.5 (3345)	83.1 (2110)	158.8 (4035)	179.7 (4565)	56 (1420)	35.1 (890)	6	8	6500 (2950)	6500 (2950)	
	139.5 (3545)	87 (2210)	166.7 (4235)	187.5 (4765)	59.9 (1520)	39.1 (990)	6	8	6500 (2950)	6500 (2950)	
Full Free-Lift 3-Stage (FSV)	159 (4045)	77.2 (1960)	186.3 (4735)	207.2 (5265)	50.1 (1270)	29.2 (745)	6	5	6500 (2950)	6500 (2950)	
	171 (4345)	83.1 (2110)	198.2 (5035)	219 (5565)	56 (1420)	35.1 (890)	6	5	6400 (2900)	6400 (2900)	
	187 (4750)	87 (2210)	213.9 (5435)	234.8 (5965)	59.9 (1520)	39.1 (990)	6	5	6300 (2860)	6300 (2860)	
	198.5 (5045)	93.3 (2370)	225.7 (5735)	246.6 (6265)	66.2 (1680)	45.4 (1150)	6	5	6150 (2790)	6150 (2790)	
	218 (5545)	100.8 (2560)	245.4 (6235)	266.3 (6765)	73.7 (1870)	52.9 (1340)	6	5	5900 (2680)	5900 (2680)	
Full Free-Lift 4-Stage (QFV) ³	237.5 (6045)	110.5 (2810)	265.1 (6735)	285.9 (7265)	83.5 (2120)	62.7 (1590)	6	5	4250 (1920)	5700 (2590)	
	241.5 (6100)	83.1 (2110)	262.6 (6670)	289.6 (7355)	62.1 (1575)	35 (890)	6	5	—	4500 (2040) ²	
	259.5 (6600)	89 (2260)	280.7 (7130)	307.7 (7815)	68 (1725)	40.9 (1040)	6	5	—	3300 (1490) ²	
	278 (7000)	95.3 (2420)	298.8 (7590)	325.8 (8275)	74.3 (1885)	47.2 (1200)	6	5	—	2100 (950) ²	

* All capacities of 1500 lbs. or less are subject to a secondary review & could be denied by Toyota.

¹ Height of standard load backrest is 48" (1220 mm).

² Requires option G00A Wide Tread.

³ QFV mast has 36"-wide Class II carriage.



4010C2

4010C3

4011C1

TOYOTA F2

TOYOTA

TOYOTA

4011D1

Some product features described herein are optional. Please consult your dealer for specifications.
Details of specifications and equipment are based on information available at time of printing and may change without notice.



INDUSTRIAL EQUIPMENT

REACH NEW HEIGHTS

007227FBCU1518SS

©2016 Toyota Material Handling, U.S.A., Inc.