

E-Series Push/Pulls



The best Push/Pull for the job.

cascade
corporation

There's no better Push/Pull for the job.

Before introducing our newest generation of push/pulls, we took a good hard look at what the materials handling market needs. Our desire wasn't to introduce just another push/pull, but to raise the standards of performance in areas that are important to our customers—and to do this at a lower price.

The Result is a Push/Pull that:

- Raises productivity by giving the driver better visibility and a faster, smoother operating attachment.
- Features the strength and durability to provide years of simple, trouble free operation.
- Delivers high net truck capacity.
- Protects both slipsheets and loads from damage.
- Provides fast, smooth operation with high pull force and low energy consumption.

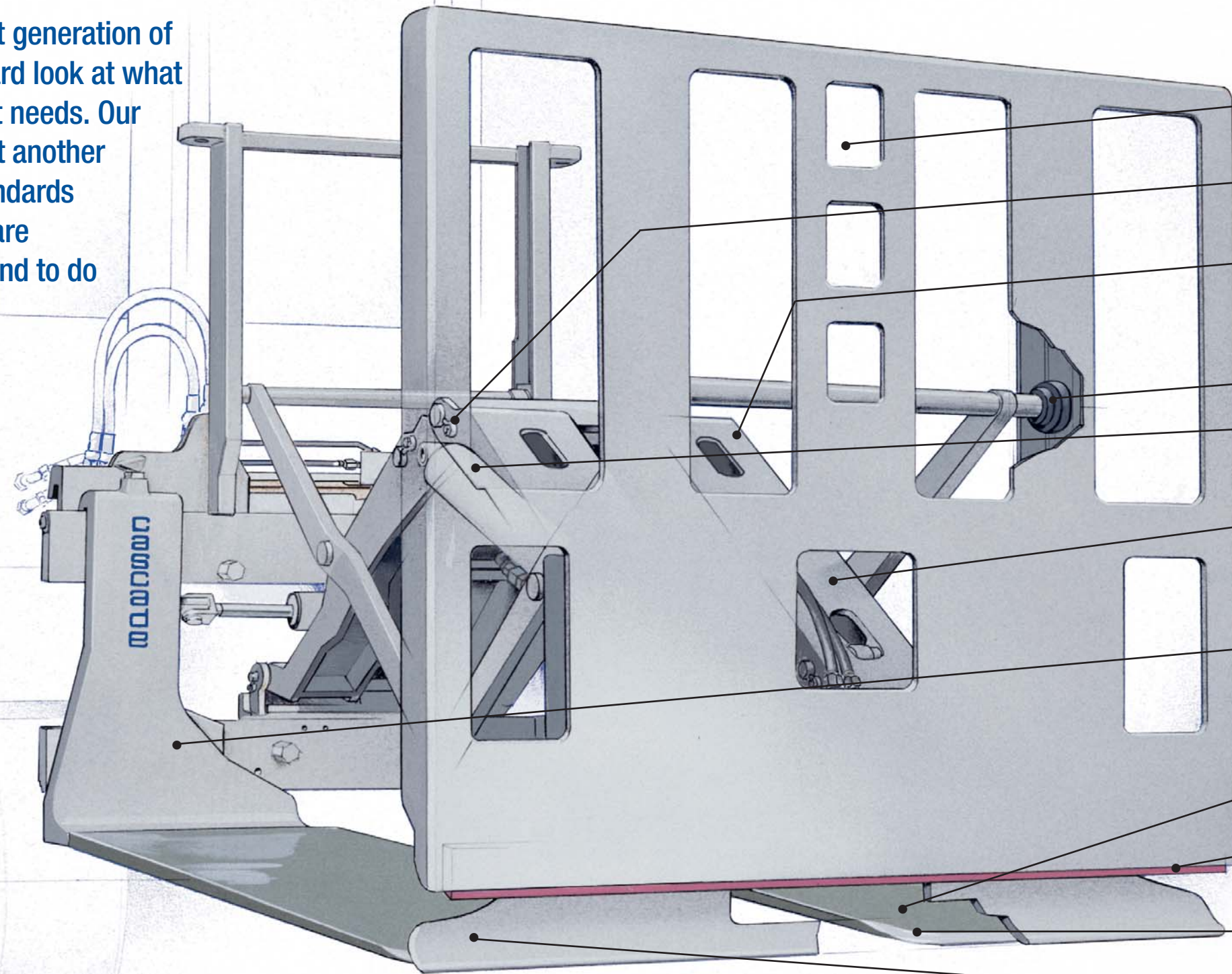

Increased visibility through center of push/pull.

Tough, wear resistant bearings require no lubrication.

Rigid double cylinder pantograph mechanism provides wider distribution of forces and pivot points.

Long life rollers.

Hydraulics are completely protected within the arms.

High strength unitized construction. Cast arms provide more strength than fabricated arms.

Platen spacing can be adjusted in seconds (carriage mount models).

Platens are fully tapered T1 steel.

Urethane gripper bar provides tight, secure grip while protecting the slip sheet.

Platen tips are chamfered to protect the slipsheet.

Gripper jaw opening handles longer tabs.



Platens are hung like conventional forks so spacing can be adjusted in seconds (carriage mount models).



Cascade's Quick-Mount system provides fast, easy sideshift installation with no modification or welding to the truck carriage and no false carriage.



Unique gripper jaw design that extends over tips of platens & 4° tilting faceplate makes it easy to engage slipsheet.



There's none better for the price.

Whatever the application, we can handle it.

35E & 45E CARRIAGE MOUNT PUSH/PULLS

All **E-Series** carriage mount push/pulls are equipped with Cascade's SIDESHIFTING feature (see A.) for unbeatable maneuverability and with Q.D. hooks for convenience. The 35E model is rated for maximum load capacity of 3,500 and 45E for 4,500 lbs. Other differences include:

The **35E/45E** is designed for short wheel-based, counter-balanced trucks in the 2,500 to 4,500 lbs. capacity range. The small truck 35E combination provides maximum net load handling capacity, short overall length and excellent maneuverability. It is ideal for truck trailer and rail car work, as well as for general slipsheet warehousing applications.

The **45E** is well suited for double load stacking applications, as well as for rail car loading and unloading.

BASE UNITS

A. Sideshifting standard on all carriage mount push/pulls.

B. Hydraulically adjustable platens.

- For applications requiring extensive pallet handling.
- Allows driver to adjust the platen spread from his seat.

C. Sideshifting platens.

- Works like basic sideshift except the frame doesn't move.
- For narrow or restricted applications.
- 200 mm sideshift capacity.

D. Load Push

- Does not have gripper mechanism to pull slipsheet.
- For loads that are scooped onto the platens.

E. Sheet Sav.®

- Allows the driver to retain the slipsheet when the load is pushed off.

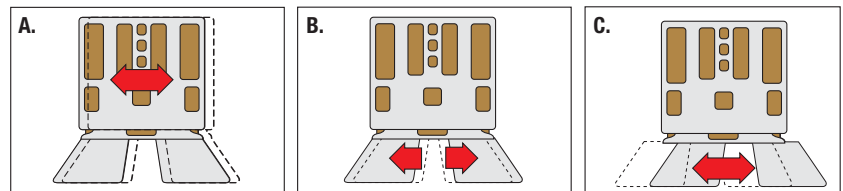
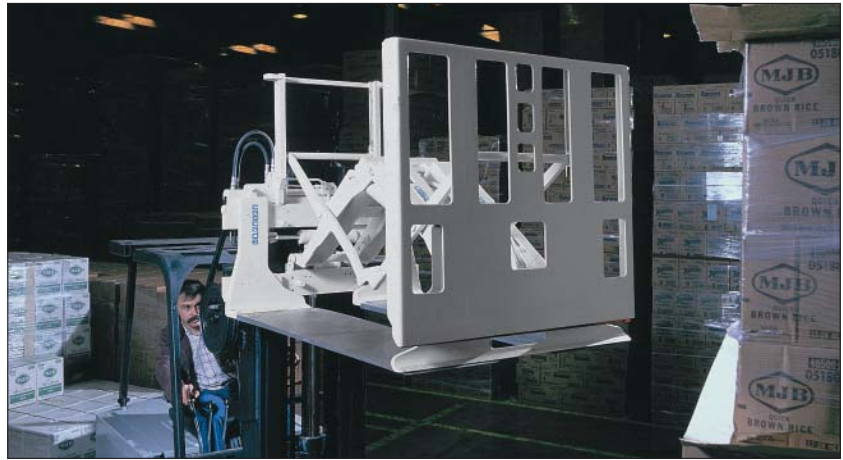

35E/45E QFM™ (QUICK FORK MOUNT) PUSH/PULLS

Our QFM models allow a standard fork truck to be converted into slipsheet truck in a matter of minutes—without removing the forks. QFM push/pulls are ideal for companies that handle slipsheets on a part time basis and use a single truck for both pallet and slipsheet handling.

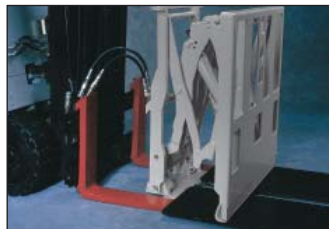

1. Position forks under platens.



2. Connect quick change hydraulic couplers.
3. Engage lower hooks.



4. QFM Push/Pull is now ready for slipsheet loads.