

LARGE ELECTRIC WALKIE PALLET JACK

 **TOYOTA**
INDUSTRIAL EQUIPMENT
REACH NEW HEIGHTS

TAKE A LOAD OFF

- ▶ 6000 lb. Capacity
- ▶ Ergonomic Multifunction Control Handle
- ▶ Regenerative Braking
- ▶ Galvanized Option



8HBW30

CLASS
3

ELECTRIC PALLET JACKS/STACKERS/TOW TRACTORS

ToyotaForklift.com

HEAVY LOADS, DELIVERED

THE TOYOTA LARGE ELECTRIC WALKIE. Power and maneuverability to handle heavy loads. Ergonomic design to maximize operator effectiveness through long shifts. The Large Electric Walkie makes loading and unloading products and traveling short distances in your warehouse or distribution center comfortably efficient and productive. Goods, delivered. Job, well done.

UP TO **3.7** MPH
TRAVEL SPEED
WITH FULL LOAD

LARGE ELECTRIC WALKIE ADVANTAGES

- ▶ **MULTIFUNCTION CONTROL HANDLE** with ergonomically positioned handgrips; dual thumbwheels; and lift, lower and horn buttons for simplified operation of all controls with either hand
- ▶ **SOLID STEEL PULL RODS** add strength throughout the entire length of forks, and are much less likely to bend or flex than push rods, resulting in less maintenance
- ▶ **HIGH-SPEED INTERLOCK** to maintain top travel speed for long-distance transport without continuously pressing a button
- ▶ **SELF-DIAGNOSTICS** simplify troubleshooting and eliminate the need for an external hand-held analyzer
- ▶ **PROGRAMMABLE PERFORMANCE PARAMETERS** customizable through a digital display to adjust for a variety of job applications and operator skill levels
- ▶ **GLANCE & GO DISPLAY** provides a quick summary of key information
- ▶ **BOX RAIL FORK CONSTRUCTION** provides torsional rigidity and maximum strength to prevent premature fatigue
- ▶ **AC DRIVE MOTOR** plus regenerative braking for longer run time and increased productivity



UP TO **6000** LB.
CAPACITY



LARGE ELECTRIC WALKIE PALLET JACK

CAPACITY
6000 LBS.

FORK SIZE
32 - 60 IN.

OVERALL FORK WIDTH
22 - 27 IN.

INDUSTRIES



Beverage



Cold Storage



Distribution



Food Storage



General
Manufacturing



General
Warehousing



Retail

STANDARD FEATURES

PERFORMANCE

- AC drive motor with thermal protection & current limiting
- 24-Volt electrical system
- 6" lift
- Fault code memory with hour meter reading
- Regenerative braking
- Programmable performance
 - Adjustable maximum speed
 - Adjustable acceleration
- On/off key switch
- Lift limit switch
- Multiple hour meter indicator
- Battery discharge indicator with lift interrupt
- Fused control & power circuits
- Hydraulic overload protection valve
- Dual 1.25"-dia. lift cylinders

DURABILITY

- Control Area Network (CAN-bus) communications
- Welded construction with reinforced heavy-duty bumper
- Powder coat paint finish
- Box rail fork construction
- Steel bulkhead wrappers
- Forged rectangular steel tension rods
- Heavy-duty bushings & pins
- Solid trail fork casting (ductile iron)
- Tapered fork tips with pallet entry slides
- Four-point lift linkage
- High-strength polymer service cover
- Rubber drive tire
- Hall-effect switches

ERGONOMICS

- Multifunction control handle with ergonomically angled handgrips & wrap-around hand guard
- Dual thumbwheels for directional control & travel speed
- Intuitively positioned lift/lower buttons
- Low-effort control handle

SERVICEABILITY

- AC drive motor (no brushes or commutator)
- Self-adjusting electric disc brake
- One-piece, lightweight service access cover
- Error indicator with self-diagnostics
- Teflon[®]-coated PolyLube™ lift linkage bushings (maintenance free)

SAFETY

- Wrap-around hand guard
- Spring-loaded control handle
- Runaway protection
- Side stabilizer steel bars
- Electric horn
- Directional reverse switch on control handle

BODY/EXTERIOR DESIGN

- SB-175 battery connector (gray)

OPTIONAL EQUIPMENT

- Upgrade to 8000 lb. load capacity
- 48," 60" and 72" load backrest extension
- Electronic travel alarm (forward & reverse)
- Controller splash guard¹
- Keyless on/off switch²
- Power hookup for onboard terminal (24-Volt, 2 amp)³
- Power hookup for onboard terminal (24-Volt, 10 amp)³
- Electronic touchpad, keyless entry system with password protection⁴
- Pallet entry/exit rollers (single length pallet forks only 36"- 60")
- Storage tray, load backrest mounted^{5, 6}
- Storage tray, battery compartment mounted^{5, 9}
- Storage tray with clipboard & stretch wrap holder, load backrest mounted^{5, 6, 10}
- Lubrication package for pivot points (grease fittings)
- Steering bearing, greaseable¹¹
- Battery compartment rollers with dual side gates⁷
- Battery side gate interlock switches⁸
- 13.44"-wide battery compartment
- Battery spacer kit
- Polyurethane drive tire¹²
- Non-marking rubber drive tire¹²
- Heavy-duty load wheels (Vulkollan®)¹³
- Load wheel debris diversion device¹⁹
- Polyurethane load wheels (tan durometer 95)¹³
- Load wheels, single axle/dual¹³
- Load wheels, single axle/triple¹³
- Cold storage conditioning^{17, 18}
- Galvanized chassis^{16, 18}
- Galvanized chassis with cold storage^{16, 18}
- Special paint color, complete truck
- UL-approved model type "E"¹⁴
- UL-approved model type "EE"¹⁵

1 Not available with option code #8087.

2 Not available with option code #8100.

3 Not available with option codes #8086 or 8087.

4 Not available with option code #8099.

5 Requires ordering option code #8092.

6 Requires optional load backrest.

7 Roller height is 8.1" (206 mm).

8 Requires option code #8018.

9 Not available with option code #8104.

10 Not available with option code #8067.

11 Required when ordering cold storage option.

12 Not available in combination with any other drive tire option.

13 Not available in combination with any other load wheel option. Option code #8201 uses sealed-type bearings. Option code #8200 uses grease fittings on axles.

14 Not available with option codes #8102 or 8103.

15 Not available with option codes #8102, 8103, 8022, 8069, 8098, 8122 or 8123.

16 Not available with option codes #8087, 8098, 8064, 110010 or 8070.

17 When ordering a galvanized truck in conjunction with an optional Load Backrest Extension, the LBR won't be galvanized.

18 Requires ordering option code #110010. Not available with option code #8087.

19 Contact your local dealer for more information on environmental conditioning.

19 Not available with option code #8077.



TRUCK SPECIFICATIONS

GENERAL DATA			MODEL NUMBER				
GENERAL DATA			8HBW30				
Load Capacity	lb (kg)		6000 (2725)				
Power Type			Battery				
Operator Position			Walkie				
Tire Type	Drive / Load		Rubber / Polyurethane				
Wheels (x = driven)	Front / Rear		1 Drive / 2 Load				
EXTERIOR DIMENSIONS			8HBW30				
A	Fork Width	in (mm)	9 (229)				
B	Overall Fork Width	in (mm)	22 (559) or 24 (610) or 27 (686)				
C	Fork Height	Lowered	3.25 (83)				
		Raised	9.25 (235)				
E	Fork Lift	in (mm)	6 (152)				
F	Fork Length	in (mm)	32 (813)	36 (914)	42 (1067)	48 (1220)	60 (1524)
G	Overall Width	in (mm)	32.5 (826)				
H	Overall Length	in (mm)	63.7 (1618)	67.7 (1720)	73.7 (1872)	79.7 (2024)	91.7 (2329)
I	Wheelbase	Lowered	46.5 (1181)	50.5 (1283)	56.5 (1435)	62.5 (1588)	74.5 (1892)
		Raised	41.8 (1062)	45.8 (1163)	51.8 (1316)	57.8 (1468)	69.8 (1773)
K	Turning Radius	in (mm)	51.4 (1306)	55.4 (1407)	61.4 (1560)	67.4 (1712)	79.4 (2017)
	Gross Weight Without Battery	lb (kg)	1000 (454)	1014 (460)	1036 (470)	1058 (480)	1108 (503)
L	Head Length	in (mm)	32.1 (815)				
M	Power Unit Height	in (mm)	31.4 (798)				
N	Overall Height	in (mm)	56.7 (1440)				
O	Distance from Control Handle to Floor (lowered position)	in (mm)	31.2 (792)				
P	Distance from Bumper to Center of Drive Tire	in (mm)	9.6 (244)				
Q	Bumper Underclearance	in (mm)	4.75 (121)				
R	Bumper Height	in (mm)	9.75 (248)				
PERFORMANCE DATA			8HBW30				
Speeds	Full Load	mph (km/h)	3.7 (6.0)				
	No Load	mph (km/h)	3.7 (6.0)				
Gradeability	Full Load	%	10				
	No Load	%	10				
TIRES			8HBW30				
	Number	Front / Rear	1 / 2				
Tires	Size (dia. x width)	Drive (front)	in (mm)	12 x 4.75 (305 x 121)			
		Load (rear)	in (mm)	3.25 x 5.91 (83 x 150)			
		Stabilizers		Steel			
POWER SYSTEM			8HBW30				
Battery	Amps Max	V / Ah	Standard	510	Optional	750	
	Voltage	V / Ah	24				
	Connector / Color	SB-175 (gray)					
	Connector Cable Location	B					
	Connector Cable Length	in (mm)	18 (457)				
	Compartment Length	in (mm)	31.5 (800) ¹				
Battery Weight	Width	in (mm)	Standard	9.20 (234)	Optional	13.44 (341)	
	Maximum	lb (kg)	Standard	1056 (480)	Optional	1500 (680)	
	Minimum	lb (kg)	Standard	490 (220)	Optional	490 (222)	
Electric Motors	Drive (60 minutes)	hp (kW)	5.5 (4.1)				

¹ Length = 30.25" (768 mm) when equipped with optional Battery Compartment Rollers.
NOTE: Exterior dimensions have been given for a standard model with a 9.20"-wide (234 mm) battery compartment.

EXTERIOR DIMENSIONS

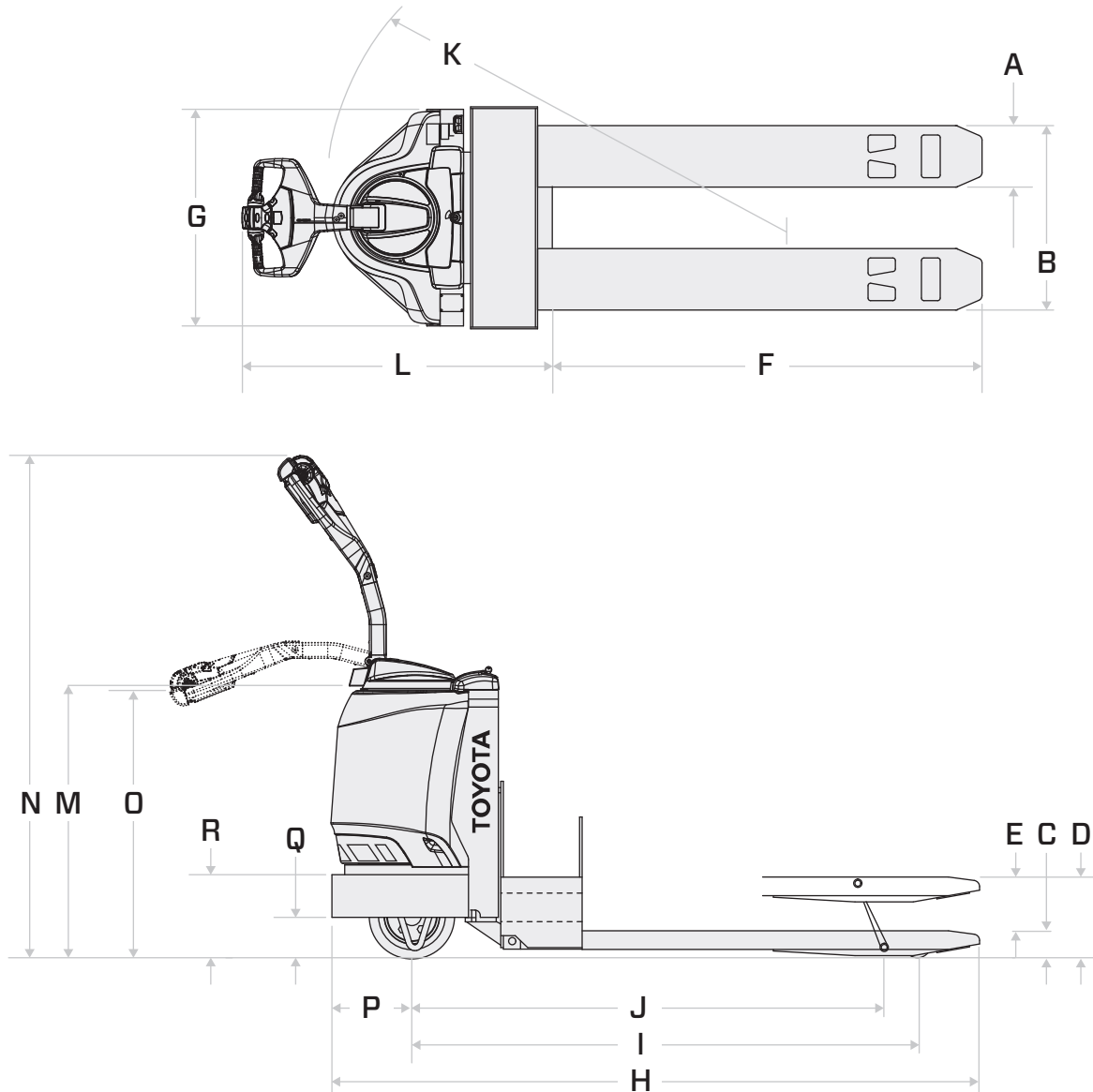

RIGHT-ANGLE STACKING AISLE REQUIREMENTS¹

FORK LENGTH	PALLET LENGTH	PALLET WIDTH						
		30 (762)	32 (813)	36 (914)	40 (1016)	42 (1067)	44 (1118)	48 (1220)
in (mm)	in (mm)	in (mm)	in (mm)	in (mm)	in (mm)	in (mm)	in (mm)	in (mm)
8HBW30								
32 (813)	32 (813)	65.2 (1656)	65.2 (1656)	65.2 (1656)	65.2 (1656)	65.2 (1656)	65.2 (1656)	65.2 (1656)
36 (914)	36 (914)	69.2 (1758)	69.2 (1758)	69.2 (1758)	69.2 (1758)	69.2 (1758)	69.2 (1758)	69.2 (1758)
42 (1067)	42 (1067)	75.2 (1910)	75.2 (1910)	75.2 (1910)	75.2 (1910)	75.2 (1910)	75.2 (1910)	75.2 (1910)
48 (1220)	48 (1220)	81.2 (2063)	81.2 (2063)	81.2 (2063)	81.2 (2063)	81.2 (2063)	81.2 (2063)	81.2 (2063)
60 (1524)	60 (1524)	93.2 (2367)	93.2 (2367)	93.2 (2367)	93.2 (2367)	93.2 (2367)	93.2 (2367)	93.2 (2367)

Minimum Aisle Width for Right-Angle Stacking¹
 Includes 4" (102 mm) clearance on each side of load.
 Add a minimum of 12" (305 mm) for easy maneuvering.

¹ Contact your local dealer for Right-Angle Stacking Aisle Requirements for option code #8092.



COUNT ON THE LEADER

- ▶ Toyota leads in quality, durability, reliability and value, thanks to advanced technology and the world-renowned Toyota Production System.
- ▶ With the broadest and most complete set of material-handling solutions in the industry, Toyota Dealers specialize in meeting all of your needs — from a single forklift to an entire fleet.
- ▶ Toyota's industry-leading network of dealers backs every forklift with proven product support. Resources include factory-trained service technicians, Toyota Genuine Parts, and flexible leasing and financing packages through Toyota Commercial Finance.

- ▶ Toyota forklifts have ranked No. 1 in safety and quality since 2002, according to studies conducted by Peerless Research Group.

For more information, including full specs, see your Toyota Dealer or ToyotaForklift.com.

 **TOYOTA**
INDUSTRIAL EQUIPMENT
REACH NEW HEIGHTS

Some product features described herein are optional. Please consult your dealer for specifications. Details of specifications and equipment are based on information available at time of printing and may change without notice.