

BIG JOE **LVE40** **SCOUT**

4,000 lb. 3-wheel Dual-drive Counterbalance Forklift



CAPACITY

4,000 lbs. at 24" load center.

BATTERY

48v UL-recognized 360Ah Li-Ion battery capable of fast charging without the need for regular maintenance or facility infrastructure such as eye wash stations or charging ventilation.

DUAL AC DRIVE MOTORS

Independently controlled dual-drive motors allow nimble control in tight spaces for superior right-angle stack and truck maneuverability.

PERFORMANCE

- Travel - 9.9 mph empty / 9.3 mph loaded
- Lift - Up to 84.6 fpm empty / Up to 68.9 fpm loaded
- Lowering - Up to 72.8 fpm empty / Up to 88.6 fpm loaded

TIRES

Front 200/50-10 solid pneumatic
Rear 15/4.5-8 solid pneumatic

OPERATOR COMPARTMENT

The operator compartment is exceptionally spacious due to the purpose-built design for an integrated lithium battery to improve ergonomics and reduce operator fatigue. A large mirror and overhead guard-mounted handrail aids the operator when driving in reverse. The platform provides a high-resolution LED display installed in the upper right corner of the cabin. At a glance, the operator can view speed, directional status, battery state-of-charge, hour meter, and more.

HYDRAULICS

The hydraulic steering system achieves more precise and responsive operation, has a simple and reliable structure, and has lower maintenance costs.

ELECTRICAL

48v AC controller technology delivers high efficiency and performance while significantly reducing maintenance costs and extending vehicle service life. The battery management system monitors lithium battery performance during operation and charging to help extend battery service life far longer than traditional lead-acid industrial batteries.

DRIVE UNIT AND BRAKES

Dual AC drive motors deliver smooth torque and speed curves matched to vehicle needs in real time for peak efficiency and performance. Regenerative neutral braking extends the duty cycle. The vehicle's regenerative brakes and automatic-actuated electromagnetic parking brake ensure effective stopping power during operation and when on rated grades.

FRAME AND MAST

Heavy-duty steel chassis features a long wheelbase, wide tires, and a low center of gravity for stable operation.

SERVICEABILITY

The onboard programmable display allows for troubleshooting and system adjustments without needing tools. Units can be optionally outfitted with a telematics system that includes cloud-based maintenance monitoring, GPS tracking, and related data services.

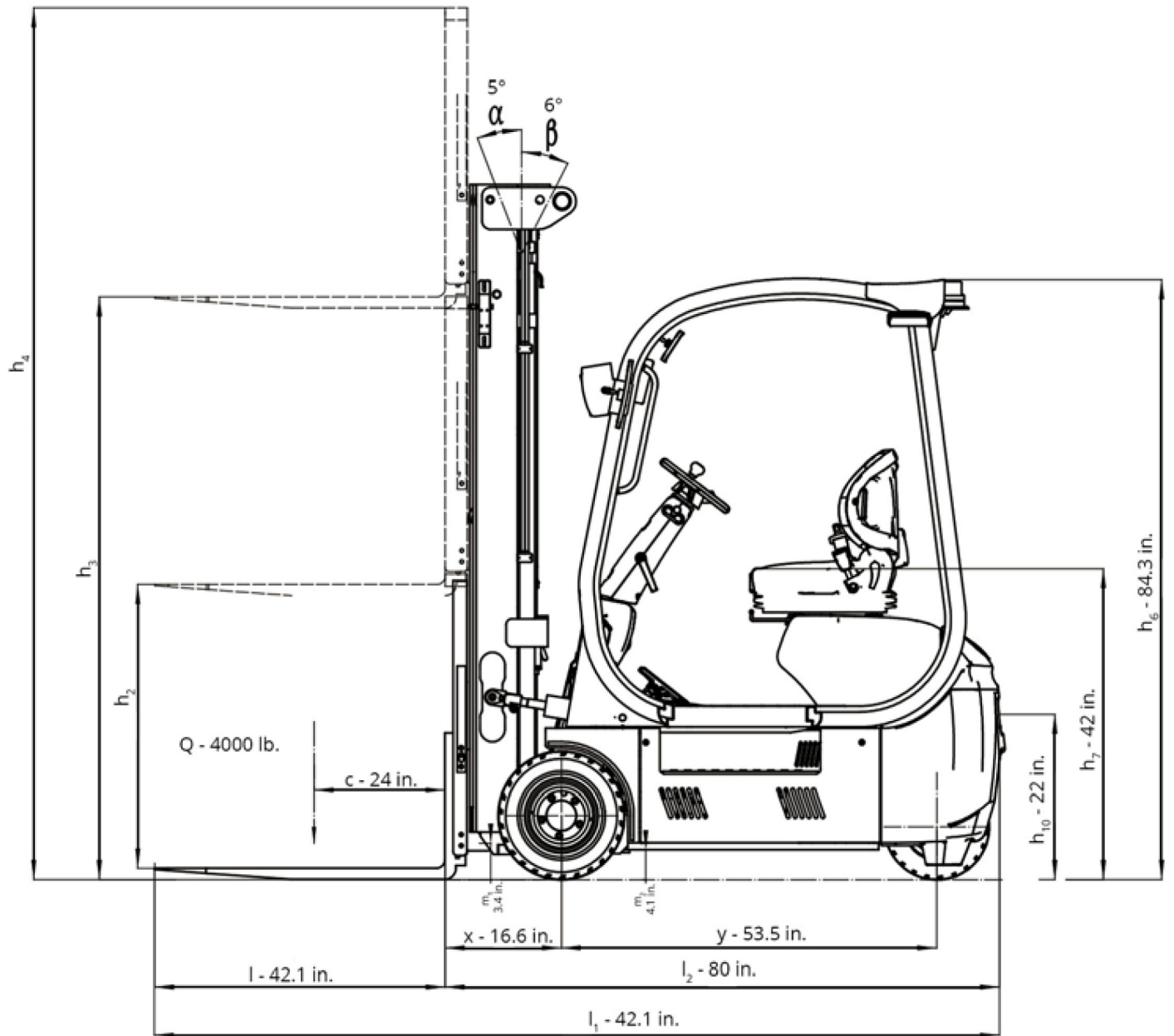

Distinguishing Marks	Drive			Electric
	Operator type			Seated
	Load capacity	Q	lb.	4000
	Load center distance	c	in.	24
	Load distance center of drive axle to fork	x	in.	16.6
	Wheelbase	y	in.	53.5
Service Weight	Service weight		lb.	8415
	Axle loading, laden front/rear		lb.	11131/1283
	Axle loading, unladen front/rear		lb.	4065/4349
Tires & Chassis	Tire type			Solid Pneumatic
	Tire size, front			200/50-10
	Tire size, rear			15/4.5-8
	Wheels, number front/rear (x=drive wheels)		in.	2X/2
	Tread width, front	b ₁₀	in.	36.9
	Tread width, rear	b ₁₁	in.	6.9

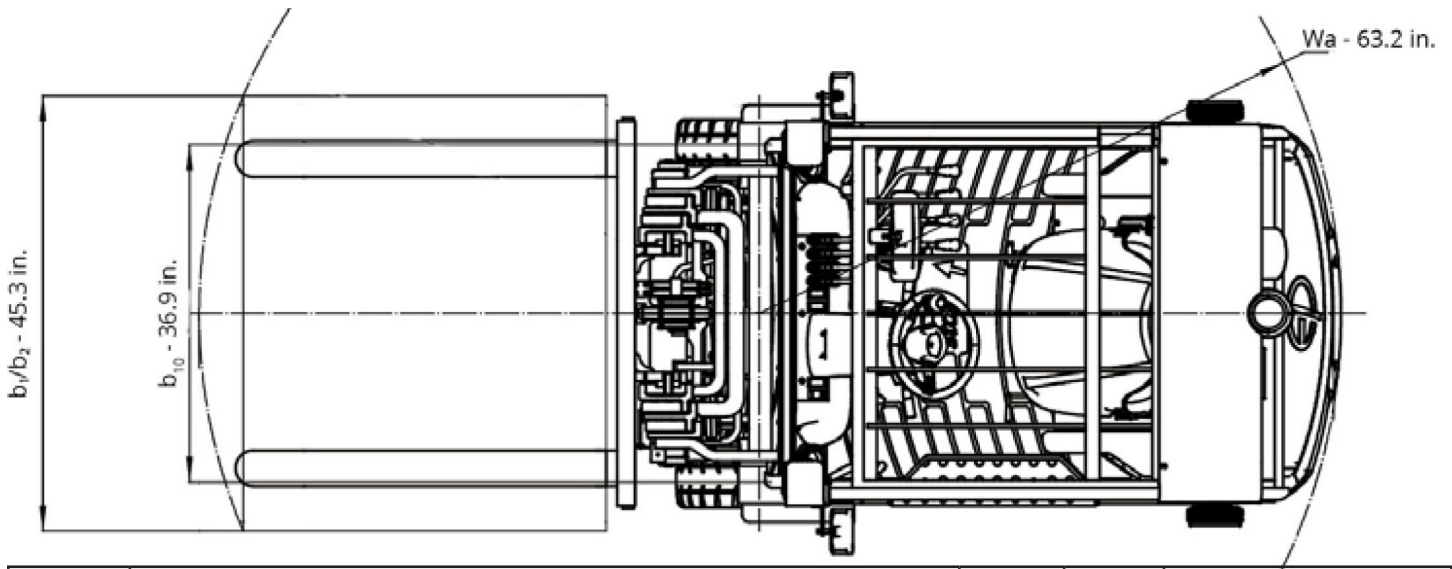

Dimensions	Tilt of mast/fork carriage forward/backward	α/β	$^\circ$	5/6
	Retracted mast height	h_1	in.	81.7
	Free lift	h_2	in.	47.8
	Lift height	h_3	in.	189
	Height, mast extended	h_4	in.	230
	Height of overhead guard (cabin)	h_6	in.	84.3
	Seat height/standing height	h_7	in.	42
	Tow coupling height	h_{10}	in.	22
	Overall length	l_1	in.	122
	Length to face of forks	l_2	in.	80
	Overall width	b_1/b_2	in.	45.3
	Fork dimensions	$s \times e \times l$	in.	1.6X4.8X42.1
	A,B Fork carriage class/type A, B			2A
	Fork carriage width	b_3	in.	41
	Ground clearance, laden, below mast	m_1	in.	3.4
	Ground clearance, center of wheelbase	m_2	in.	4.1
	Right Angle Stack= $X + Wa$. (Add load length + Clearance)		in.	79.8
	Turning radius	Wa	in.	63.2
Performance	Travel speed, laden/unladen		mph	9.3/9.9
	Lifting speed, laden/unladen		fpm	68.9/84.6
	Lowering speed, laden/unladen		fpm	88.6/72.8
	Max. gradeability, laden/unladen		%	15/17
Brakes	Service brake			Regen
	Parking brake			Electromagnetic
Components	Drive motor rating S2 60 min		kW	5.4X2
	Lift motor rating at S3 15%		kW	11
	Battery voltage/nominal capacity		V/Ah	48V/360Ah
	Battery weight		lb.	456
	Type of drive control			AC
Additional data	Operating pressure for attachments		PSI	3050
	Oil flow for attachments		gpm	5.3
	Steering design			Hydraulic
	Sound pressure level at the driver's ear		dB(A)	79
	Charger output current		A	25, 50, 150

STANDARD FEATURES

- Rear Blue light Standard
- Headlights, Brake Lights, Turn Signals, Warning Light
- Telematics
- Back up alarm
- Rear Grab Bar with Horn
- Solid Pneumatic Tires
- Adjustable suspension seat with armrests
- Integral side shifter with 3-function hydraulics
- **189" Mast 3 Stage with Free Lift**
- 42" Forks
- 42" Load Backrest
- 48V360ah Li-Ion UL Battery
- Accessory on-board Power/Charging
- Cup Holder
- LED Display with Bluetooth Connectivity
- Rearview mirror

OPTIONAL EQUIPMENT

- 197" Mast 3 Stage with Free Lift
- 48" Forks
- 48" LBR
- 60" LBR
- No side Shifter with 4-function hydraulics
- Hang-on Side Shifter with 4-function hydraulics
- Side Shifting Fork Positioner with 4-function hydraulics
- LED Rear Light
- Front Blue Light
- Red Curtain Lights
- Non-Marking Tires
- Internal Charger 120/240VAC Input, 25/50A output
- External Charger 120VAC Input, 30A output
- External Charger 240VAC Input, 60A output
- External Charger 208/220/240 3ph Input, 150A Output
- External Charger 480VAC 3ph Input, 160A Output



Learn more at bigjoeforklifts.com
630-916-2600
sales@bigjoeforklifts.com
2777 Finley Rd., Ste 16 Downers Grove, IL 60515

Certification

All units are built to be in compliance with ANSI B56.1 and the Occupational Safety & Health Act (OSHA). Big Lift LLC will not assume liability for injuries or damage arising from, or caused by, the removal of any safety devices from their vehicles by user. Because of the Big Lift LLC continuing product improvements, specifications are subject to change without notice.