

# CENTER-CONTROLLED RIDER AND CORE TOW TRACTOR



# AUTOMATED WORKHORSE

- ▶ Natural Features Navigation (LIDAR)
- ▶ Up to 10,000 lb. Towing Capacity
- ▶ Up to 7,000 lb. Lifting Capacity
- ▶ Little to No Infrastructure Required
- ▶ Tight Turning Radius





# TRUSTED EQUIPMENT MEETS PROVEN AUTOMATION

Gaining a competitive advantage in manufacturing, warehousing, and distribution requires implementation of cutting-edge technology and optimized processes.

Toyota's Center-Controlled Rider and Core Tow Tractor automated forklifts merge the latest automation technologies with industry-leading equipment, providing seamless, and efficient material handling while effectively reducing your operating costs.

Each AGV is powered by LIDAR-based natural features navigation, which requires little to no additional infrastructure or burdensome setup. We create a map of the area in which the AGV will work in and let the equipment handle the rest.

Need to adjust your process, add a new unit, or alter a route? We'll train your staff to use the software so you can make adjustments on your own – effectively minimizing your downtime with no service or subscription fees required.



# PREDICTABLY CONSISTENT, REMARKABLY ACCURATE

Toyota's Center-Rider and Core Tow Tractor automated forklifts utilize advanced sensors to detect obstacles and slow or stop the vehicle when an unmapped object is detected in its path. Cutting-edge geometry can even detect mapped structures behind objects, meaning an errant pallet or object won't interrupt normal operation.

Your business relies on accurate and repeatable results, day in and day out. Toyota's automated forklifts offer an accuracy tolerance as narrow as 0.5" when positioning and maneuvering loads, allowing you to confidently set it and forget it.

Seamless. Efficient. Accurate. Let Toyota's automated guided forklifts get to work for you today.



## QUALITY YOU CAN RELY ON

Toyota's Center-Controlled Rider and Core Tow Tractor automated forklifts utilize our industry-leading, Class III forklifts as a base – allowing them to be operated manually as needed. Each model is built using the Toyota Production System and Toyota Genuine Parts, providing superior quality, reliability, and durability.

In the event your equipment does require service, it's fast and efficient by design. Each Toyota automated forklift is backed by Toyota 360 Support, providing you with 4-hour guaranteed response times, access to our exclusive service app, and over 3,500+ Toyota Certified Technicians. With Toyota, your operation will be up and running day or night, shift after shift.



TECHNICAL SUPPORT AVAILABLE

## BENEFITS OF AUTOMATION:



Improve throughput and efficiency with process optimization.



Reduce overall labor and operational costs.



Reduce operational variances associated with manual operation.



Free up labor to perform work that adds value and is less repetitive.



Leverage advanced technologies to promote reliable operation.



# AN INVESTMENT WORTH MAKING

**DECIDING WHETHER TO INVEST** in automation ultimately depends on your return on investment (ROI). Calculating ROI can be a complicated process, but you're not alone. Toyota dealers offer free site surveys to determine your unique needs and provide you with key insights, allowing you to make confident, smart business decisions.

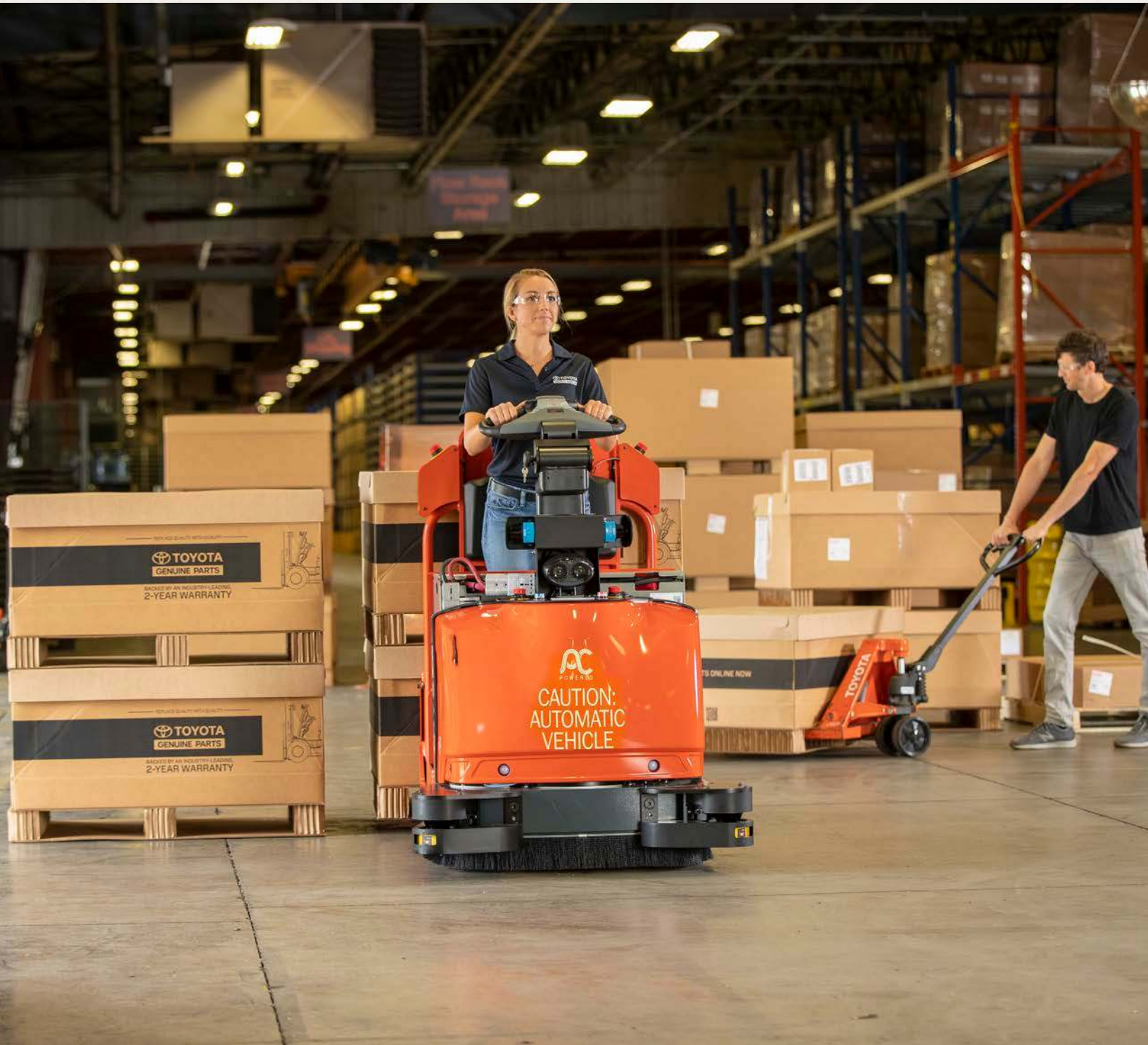





# YOUR TRUSTED MATERIAL HANDLING SOLUTIONS PROVIDER

With Toyota, you gain more than just an automation partner. You gain a full-line material handling solutions provider capable of handling all of your material handling needs. Everything from conveyors to AS/RS systems, from hand pallet jacks to container handlers, can be sold and serviced by your local Toyota forklift dealer.

We're also here to help support you throughout your entire optimization journey. Toyota dealers leverage our industry-leading product portfolio and Toyota Lean Management principles to provide you with the right solution at the right time.

You deserve people and solutions you can trust. Contact your local Toyota dealer today for a free site survey and start your automation journey today.

# CENTER-CONTROLLED RIDER AND CORE TOW TRACTOR AUTOMATED FORKLIFTS

## CAPACITY

**8000 - 10000 LBS.**

## TECHNOLOGY

**LIDAR**

## VOLTAGE

**24**

### INDUSTRIES



General  
Manufacturing



General  
Warehousing



Cold  
Storage



Distribution



Factory



Food  
Storage

## STANDARD FEATURES

### PERFORMANCE

- AC drive motor with thermal protection & current limiting
- 24-Volt electrical system
- Fault code memory with hour meter reading
- Regenerative braking
- Programmable performance
  - Adjustable maximum speed
  - Adjustable acceleration
- On/off key switch
- Lift limit switch<sup>4</sup>
- Multiple hour meter indicator
- Battery discharge indicator
- Fused control & power circuits
- Hydraulic overload protection valve<sup>4</sup>
- Dual 1.25 inch diameter lift cylinders<sup>4</sup>

### BODY/EXTERIOR DESIGN

- 31.5"-long x 13.44"-wide battery compartment<sup>3,4</sup>
- 31.75"-long x 13.44"-wide battery compartment<sup>5</sup>
- SB-175 battery connector (gray)
- Wrap-around hand guard
- Control handle with dual brake levers
- Heavy-duty spring-loaded stabilizing casters<sup>2,4</sup>
- Polyurethane torsion block stabilizing casters<sup>1,5</sup>
- Electronic horn
- Forward-facing blue light
- LED system indicators

### ERGONOMICS

- Multifunction control handle with ergonomically angled handgrips & wrap-around hand guard
- Dual thumbwheels with twist grips for directional control & travel speed
- Intuitively positioned lift/lower buttons
- Horn button
- High-speed interlock button
- Bubble-cushioned operator floor mat, padded backrest & knee pad
- Walk-through operator compartment
- Low platform step height
- Axle weldment rubber suspension system<sup>5</sup>
- Low-effort power steering with adjustable height control handle

### DURABILITY

- Control Area Network (CAN-bus) communications
- Welded construction with reinforced heavy-duty bumper
- Powder coat paint finish
- Box rail fork construction<sup>4</sup>
- Steel bulkhead wrappers
- Forged rectangular steel tension rods<sup>4</sup>
- Heavy-duty bushings and pins<sup>4</sup>
- Solid rail fork casting<sup>4</sup>
- Tapered fork tips with pallet entry slides<sup>4</sup>
- Four-point lift linkage<sup>4</sup>
- High-strength polymer service cover
- Poly drive tire
- Polyurethane rear wheels (durometer 95)
- Hall-effect switches
- Axle weldment rubber suspension system<sup>5</sup>
- Load backrest extension (48 inch)

### SERVICEABILITY

- AC drive motor (no brushes or commutator)
- One-piece, lightweight service access cover
- Teflon coated Polylube™ lift linkage bushings (maintenance free)<sup>4</sup>
- Error indicator with self-diagnostics
- Self-adjusting electric disc brake

### AUTOMATION

- Natural features navigation
- Velocity drive LIDAR safety field
- Dual LIDAR scanners
- Cantilevered load detection
- Complete traffic control
- Fork tip sensors<sup>4</sup>
- Load detection on forks<sup>4</sup>
- LCD system display
- BlueBotics controller

<sup>1</sup> Standard only with fork lengths below 84" (2134 mm).

<sup>2</sup> Standard only with fork lengths 84" (2134 mm) & above.

<sup>3</sup> Battery compartment width is 30.25" (768 mm) when equipped with optional battery compartment rollers.

<sup>4</sup> Available on Center-Controlled Rider Automated Forklift only.

<sup>5</sup> Available on Core Tow Tractor Automated Forklift only.

## OPTIONAL EQUIPMENT

- Load backrest extension (60")<sup>1</sup>
- Keyless on/off switch
- Power hookup for onboard terminal (24-Volt, 2 amp)
- Power hookup for onboard terminal (24-Volt, 10 amp)
- Storage tray, battery compartment mounted
- Flat back pad
- Automatic coupler tow hitch<sup>2</sup>
- Pin & clevis tow hitch<sup>2</sup>
- Battery compartment rollers with dual side gates<sup>1</sup>
- Battery side gate interlock switches<sup>1</sup>
- 32"-high battery retaining wall height
- Multiple battery connector options
- Automatic charging<sup>2</sup>
- Floor scanner
- Flap sensor extension<sup>1</sup>
- Heavy-duty load wheels (Vulkollan)<sup>1</sup>
- Tandem dual load wheels<sup>1</sup>
- Load wheel debris diversion device<sup>1</sup>
- Polyurethane load wheels (Durometer 95)<sup>1</sup>
- Heavy-duty spring-loaded stabilizing casters<sup>2</sup>
- Heavy-duty spring-loaded stabilizing casters with food grade grease
- Various fork lengths<sup>1</sup>

<sup>1</sup> Available on Center-Controlled Rider Automated Forklift only.

<sup>2</sup> Available on Core Tow Tractor Automated Forklift only.

Please contact your local, authorized Toyota Dealer for a complete list of available options.



Optional equipment can affect specifications and design.



## TRUCK SPECIFICATIONS

GENERAL DATA			MODEL NUMBER				
GENERAL DATA			8TB50A				
Load Capacity <sup>1</sup>	lb (kg)		10000 (4540)				
Power Type	Battery						
Operator Position	Center-Controlled Rider						
Tire Type	Drive / Caster / Load		Polyurethane / Polyurethane / Polyurethane				
Wheels (x = driven)	Front / Rear		1 Drive, 2 Casters / 2 Rear				
EXTERIOR DIMENSIONS			8TB50A				
<b>A</b>	Overall Width	in (mm)	39.94 (1014)				
<b>B</b>	Overall Length	in (mm)	57.97 (1472)				
<b>C</b>	Wheelbase	in (mm)	37.38 (949)				
<b>D</b>	Turning Radius	in (mm)	55.84 (1418)				
<b>E</b>	Power Unit Height	in (mm)	32.32 (821)				
<b>F</b>	Handle Height Adjustment Range	in (mm)	48.81 (1240) - 53.54 (1360)				
<b>G</b>	Operator's Platform Height	in (mm)	8.18 (208)				
<b>H</b>	Operator's Platform Depth	in (mm)	15.55 (395)				
<b>I</b>	Distance from Bumper to Center of Drive Tire	in (mm)	14.65 (372)				
<b>J</b>	Bumper Underclearance	in (mm)	2.94 (75)				
<b>K</b>	Bumper Height	in (mm)	9.84 (250)				
	Gross Weight Without Battery	lb (kg)	1244(565)				
PERFORMANCE DATA			8TB50A				
Travel Speed (Manual)	Full Load	mph (km/h)	5.8 (9.3)				
	No Load	mph (km/h)	8.8 (14.2)				
Travel Speed (Automated) <sup>2</sup>	Full Load	mph (km/h)	4.0 (6.5)	3.5 (5.4)	2.7 (4.3)	1.5 (2.5)	1.1 (1.8)
	Capacity	lb (kg)	4850 (2200)	70540 (3200)	8487 (3800)	9259 (4200)	10008 (4540)
Drawbar Pull	Continuous	lb (kg)	250 (114)				
	Maximum	lb (kg)	750 (341)				
TIRES			8TB50A				
Tires	Number	Front / Rear	3 / 2				
	Size (dia. x width)	Drive (front)	in (mm)	12 x 4.75 (305 x 121)			
		Caster (front)	in (mm)	4 x 2.5 (102 x 64)			
		Rear	in (mm)	6 x 3.25 (152 x 82)			
POWER SYSTEM			8TB50A				
Battery	Voltage/Capacity	V / Ah	24 / 750				
	Connector (Color)		SB-175 (gray)				
	Connector Cable Location		B				
	Connector Cable Length	in (mm)	18 (457)				
Battery Compartment	Width	in (mm)	31.75 (806)				
	Length	in (mm)	13.44 (341)				
	Height	in (mm)	-				
Battery Weight	Maximum	lb (kg)	1500 (680)				
	Minimum	lb (kg)	980(445)				
Electric Motors	Drive (60 minutes)	hp (kW)	5.5 (4.1)				
Control Type	Drive		-				
	Load Handling		-				

<sup>1</sup> Capacity for manual mode only.

<sup>2</sup> Capacity for automated mode only. Travel speed is based upon rated capacity.



# EXTERIOR DIMENSIONS

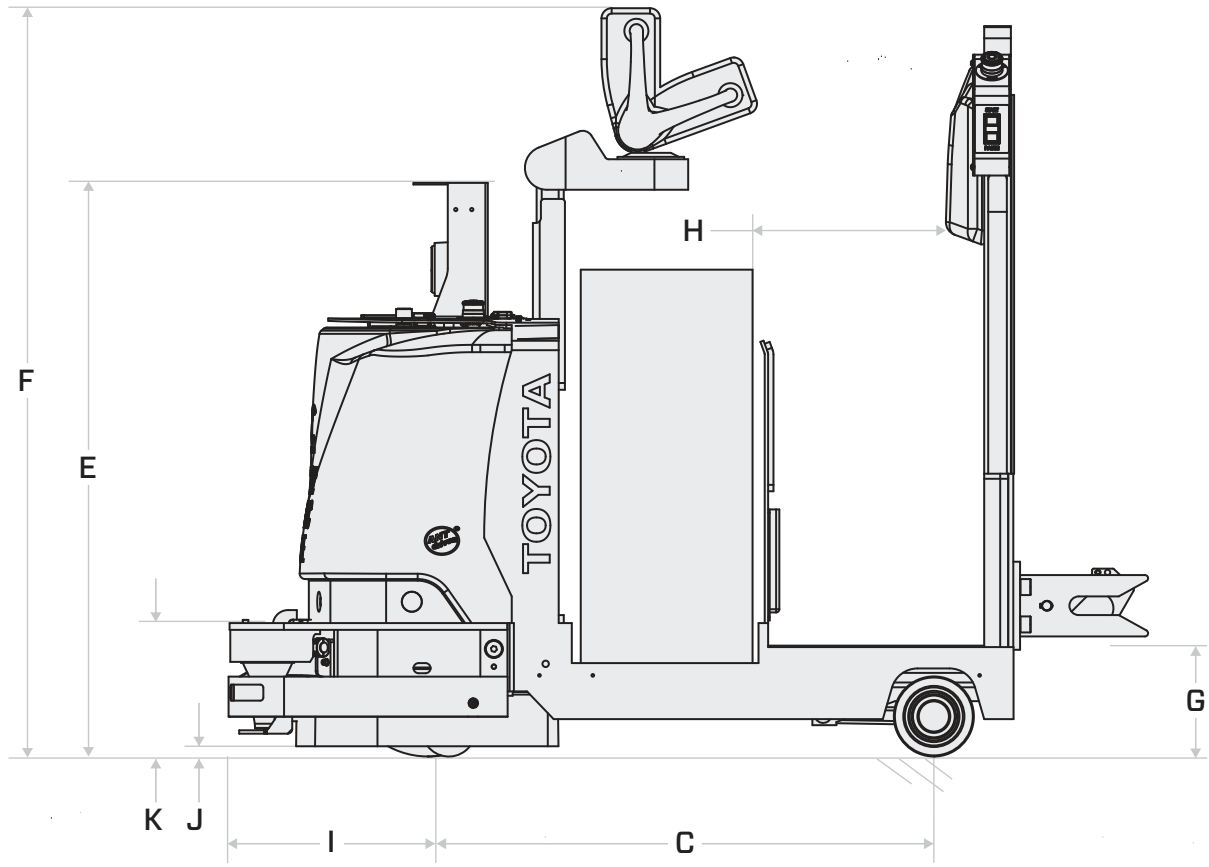
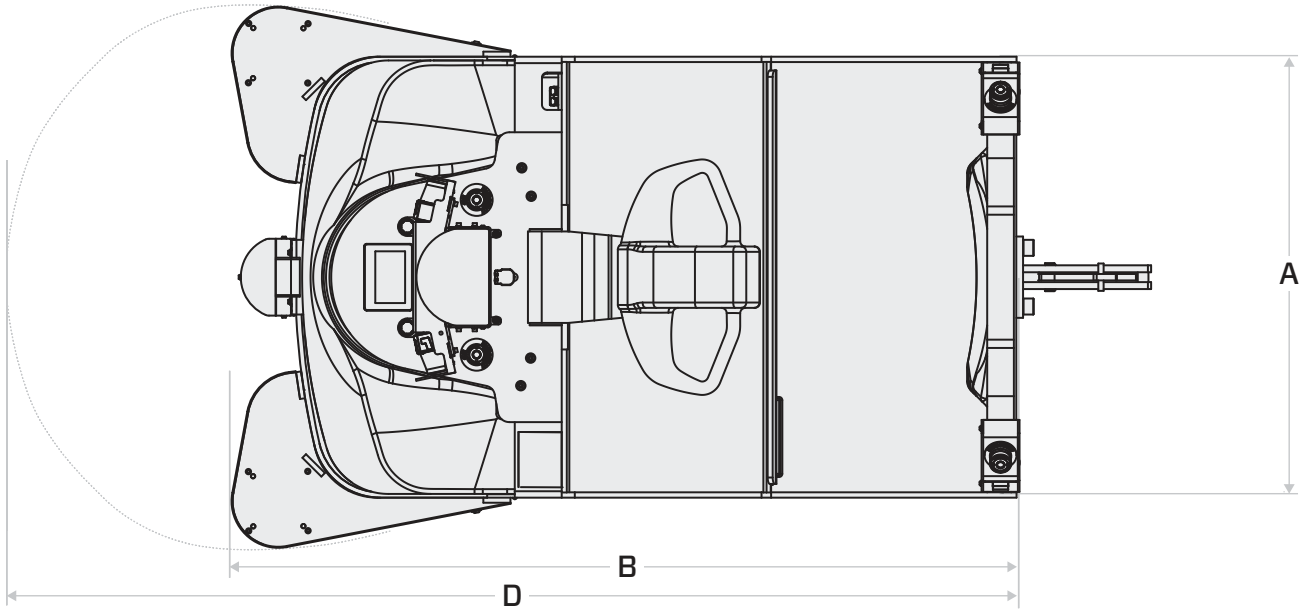

## TRUCK SPECIFICATIONS

GENERAL DATA			MODEL NUMBER				
GENERAL DATA			8HBC40A				
Load Capacity	lb (kg)		8000 (2725)				
Power Type			Battery				
Operator Position			Center-Controlled Rider				
Tire Type	Drive / Caster / Load		Polyurethane / Polyurethane / Polyurethane				
Wheels (x = driven)	Front / Rear		1 Drive, 2 Heavy-Duty Casters / 2 Load				
EXTERIOR DIMENSIONS			8HBC40A				
<b>A</b> Fork Width	in (mm)		10 (254)				
<b>B</b> Overall Fork Width	in (mm)		27.5 (699)				
<b>C</b> Fork Height	Lowered	in (mm)	3.25 (83)				
	Raised	in (mm)	9.25 (235)				
<b>E</b> Fork Lift	in (mm)		6 (152)				
<b>F</b> Fork Length	in (mm)		84 (2134) <sup>1,2,6</sup>		96 (2438) <sup>1,2,6</sup>		
<b>G</b> Overall Width	in (mm)		32.5 (826)				
<b>H</b> Overall Length	in (mm)		138.75 (3524)		148.75 (3778)		
<b>I</b> Wheelbase	Lowered	in (mm)	105.2 (2672)				
	Raised	in (mm)	100.55 (2553)				
<b>K</b> Turning Radius	in (mm)		106.6 (2708)		106.6 (2708)		
Gross Weight Without Battery	lb (kg)		1730 (785)		1780 (807)		
<b>L</b> Head Length	in (mm)		58.9 (1497)				
<b>M</b> Power Unit Height	in (mm)		32.3 (821)				
<b>N</b> Overall Height (handle)	Adjustment Range	in (mm)	46.82 (1189) to 51.62 (1311)				
<b>O</b> Operator's Platform Height	Lowered	in (mm)	4.4 (112)				
	Raised	in (mm)	9.7(247)				
<b>P</b> Operator's Platform Depth	in (mm)		16.84 (428)				
<b>Q</b> Distance from Bumper to Center of Drive Tire	in (mm)		14.65 (372)				
<b>R</b> Bumper Underclearance	in (mm)		2.94 (75)				
<b>S</b> Bumper Height	in (mm)		9.84 (250)				
PERFORMANCE DATA			8HBC40A				
Travel Speed (Manual)	Full Load	mph (km/h)	6.2 (10.0)				
	No Load	mph (km/h)	8.8 (14.2)				
Travel Speed (Automated) <sup>8</sup>	Full Load	mph (km/h)	5 (8.0)	4.3(6.9)	3.5 (5.7)	2.7 (4.3)	2.7 (4.3)
	Capacity	lb (kg)	5732 (2600)	6172 (2800)	7054 (3200)	7054 (3200)	7054 (3200)
Gradeability <sup>9</sup>	Full Load	%	8				
	No Load	%	10				
TIRES			8HBC40A				
Tires	Number	Front / Rear	3 / 2				
	Size (dia. x width)	Drive (front)	in (mm)	12 x 4.75 (305 x 121)			
		Caster (front)	in (mm)	4 x 2.5 (102 x 64)			
		Load (rear)	in (mm)	3.25 x 5.91 (83 x 150)			
POWER SYSTEM			8HBC40A				
Battery	Voltage/Capacity	V / Ah	24 / 750				
	Connector (Color)		SB-175 (gray)				
	Connector Cable Location		B				
	Connector Cable Length	in (mm)	18 (457)				
Battery Compartment	Width	in (mm)	31.5 (800) <sup>4</sup>				
	Length	in (mm)	13.44 (341)				
	Height	in (mm)	-				
Battery Weight	Maximum	lb (kg)	1500 (680)				
	Minimum	lb (kg)	980 (445)				
Electric Motors	Drive (60 minutes)	hp (kW)	5.5 (4.1)				
Control Type	Drive		-				
	Load Handling		-				

1 48" (1219 mm) load backrest extension is standard.  
 2 Forks are designed to handle two 48" (1219 mm) long pallets.  
 3 These forks have a 7" (178 mm) longer wheelbase to allow for load overhang & proper load wheel drop.  
 4 Length = 30.25" (768 mm) when equipped with optional Battery Compartment Rollers.  
 5 Polyurethane Torsion Block Stabilizing Casters are standard.  
 6 Heavy-Duty Spring-Loaded Stabilizing Casters are standard.  
 7 Capacity for manual mode only. See chart on page 11 for automated lifting capacities.  
 8 Capacity for automated mode only. Travel speed is based upon rated capacity.  
 9 Maximum rated slope in automated mode is 3%.



# EXTERIOR DIMENSIONS

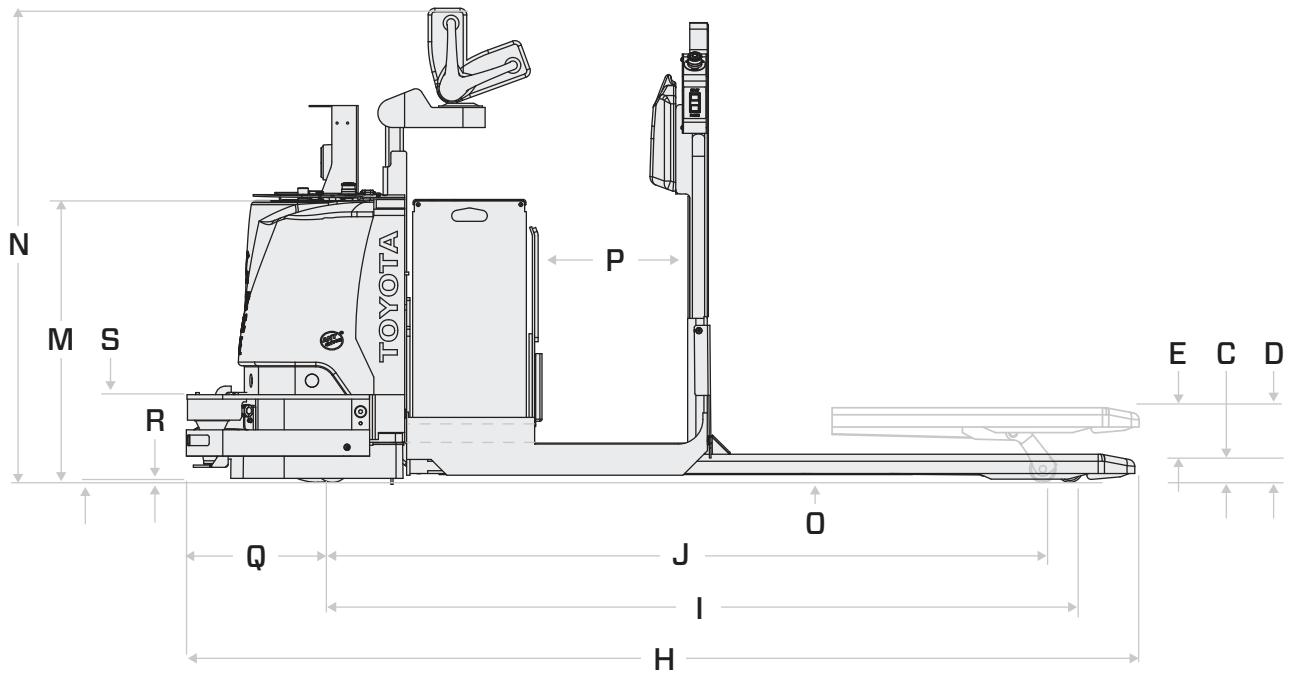
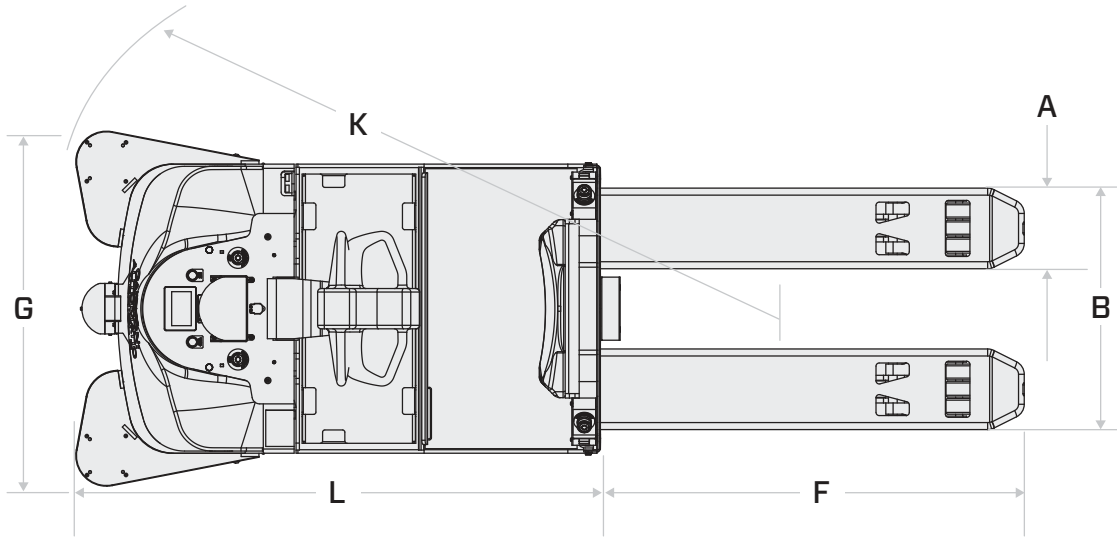



“THE NAME ON MY SHIRT  
SAYS TOYOTA,  
BUT I WORK  
FOR YOU.”

Alan – 360 Technician, Atlas Toyota Material Handling, Chicago, IL



**HELP IS ALWAYS HERE WITH TOYOTA 360 SUPPORT.**

The industry’s best and most comprehensive dealer network quickly delivers Toyota Certified Technicians to your work site. These specially trained technicians can also help assess your warehouse and facility needs to recommend the right equipment for the job. And with the largest fleet of used and rental material handling products, Toyota 360 keeps your business running at full speed.

[ToyotaForklift.com/360-Support](http://ToyotaForklift.com/360-Support)



**YOUR BUSINESS IS RIDING ON IT.**

Some product features described herein are optional. Please consult your dealer for specifications. Details of specifications and equipment are based on information available at time of printing and may change without notice.

