

4-Wheel Pneumatic Forklift 4000lbs

CPD20L1

EP
Let's grow together



- **IPX4 rated designed for indoor/outdoor applications**
- **48V system using EP Energy's 360Ah lithium battery and AC Drive Motor**
- **Wide variety of external chargers up to 150A**
- **Ergonomic design with ample cabin space, adjustable steering, and suspension seat**

Manufacturer	EP		
Model designation	CPD20L1		
Drive	Electric		
Base capacity	Q	lb.	4000
Load center distance	c	in.	24
Service weight		lb.	7892
Collapsed Height	h1	in.	84.4
Maximum fork height	h3	in.	189
Height, mast extended with Std. LBR	h4	in.	229
Length to face of forks	l2	in.	86.6
Overall width	b1/b2	in.	42.5
Fork dimensions	s/e/l	in.	1.57x4.8x42.12
Turning radius	Wa	in.	81.89
Travel speed, loaded/unloaded		mph	6.5/8.7
Lifting speed, loaded/unloaded		fpm	55.1/82.6
Lowering speed, loaded/unloaded		fpm	84.6/88.6
Max. gradeability, loaded/unloaded		%	10.5/14
Drive motor rating S2 60 min		kW	6
Battery voltage/nominal capacity		V/Ah	48V/360Ah

4-Wheel Pneumatic Forklift 4000lbs CPD20L1

Distinguishing mark	1.1	Manufacturer				EP	EP
	1.2	Model designation				CPD20L1	CPD20L1
	1.3	Drive				Electric	Electric
	1.4	Operator type				Seated	Seated
	1.5	Base capacity	Q	lb.		4000	4000
	1.6	Load center distance	c	in.		24	24
	1.8	Load distance, center of drive axle to fork	x	in.		15.94	15.94
	1.9	Wheelbase	y	in.		57.87	57.87
	Service weight	2.1	Service weight		lb.		7892
2.2		Axle loading, loaded front/rear		lb.		10262/1598	11312/1598
2.3		Axle loading, unloaded front/rear		lb.		3582/4310	3632/4310
Tires/chassis	3.1	Tire type				Solidrubber	Solidrubber
	3.2	Tire size, front				200/50-10	200/50-10
	3.3	Tire size, rear				5.00-8	5.00-8
	3.5	Wheels, number front/rear (x=drive wheels)		in.		2x/2	2x/2
	3.6	Tread width, front	b ₁₀	in.		35.8	35.8
	3.7	Tread width, rear	b ₁₁	in.		36.22	36.22
Dimensions	4.1	Tilt of mast/fork carriage forward/backward	α/β	°		6/11	6/11
	4.2	Collapsed Height	h ₁	in.		84.4	87
	4.3	Free lift	h ₂	in.		44	46.5
	4.4	Maximum fork height	h ₃	in.		189	197
	4.5	Height, mast extended with Std. LBR	h ₄	in.		229	237
	4.7	Height of overhead guard (cabin)	h ₆	in.		81.89	81.89
	4.8	Seat height/standing height	h ₇	in.		41.34	41.34
	4.12	Tow coupling height	h ₁₀	in.		14.17	14.17
	4.19	Overall length	l ₁	in.		128.74	128.74
	4.20	Length to face of forks	l ₂	in.		86.6	86.6
	4.21	Overall width	b ₁ /b ₂	in.		42.5	42.5
	4.22	Fork dimensions	s×e×l	in.		1.57x4.8x42.12	1.57x4.8x42.12
	4.23	A,B Fork carriage class/type A, B				2A	2A
	4.24	Fork carriage width	b ₃	in.		40.94	40.94
	4.31	Ground clearance, loaded, below mast	m ₁	in.		4.33	4.33
	4.32	Ground clearance, center of wheelbase	m ₂	in.		4.13	4.13
4.34.1	Right Angle Stack (x +wa)	Ast	in.		97.83	97.83	
4.34.2	Minimum Aisle Width (Right Angle Stack + Load Length + Clearance)	Ast	in.		157.83	157.83	
4.35	Turning radius	Wa	in.		81.89	81.89	
Performance data	5.1	Travel speed, loaded/unloaded		mph		6.5/8.7	6.5/8.7
	5.2	Lifting speed, loaded/unloaded		fpm		55.1/82.6	55.1/82.6
	5.3	Lowering speed, loaded/unloaded		fpm		84.6/88.6	84.6/88.6
	5.6	Max. drawbar pull, loaded/unloaded		lbf		2247	2247
	5.8	Max. gradeability, loaded/unloaded		%		10.5/14	10.5/14
	5.10	Service brake				Electromagnetic	Electromagnetic
5.11	Parking brake				Electromagnetic	Electromagnetic	
Electric-engine	6.1	Drive motor rating S2 60 min		kW		6	6
	6.2	Lift motor rating at S3 15%		kW		7.5	7.5
	6.4	Battery voltage/nominal capacity		V/Ah		48V/360Ah	48V/360Ah
	6.5	Minimum battery weight		lb.		450	450
Additional data	8.1	Type of drive control				AC	AC
	10.5	Steering design				Hydraulic	Hydraulic
	10.7	Sound pressure level at the driver's ear		dB(A)		70	70
	15.1	Charger output current		A		25, 50, 150	25, 50, 150

If there are improvements of technical parameters or configurations, no further notice will be given.
The diagram shown may contain non-standard configurations.
Minimum Aisle Width uses 48" for load length and 12" for Clearance.

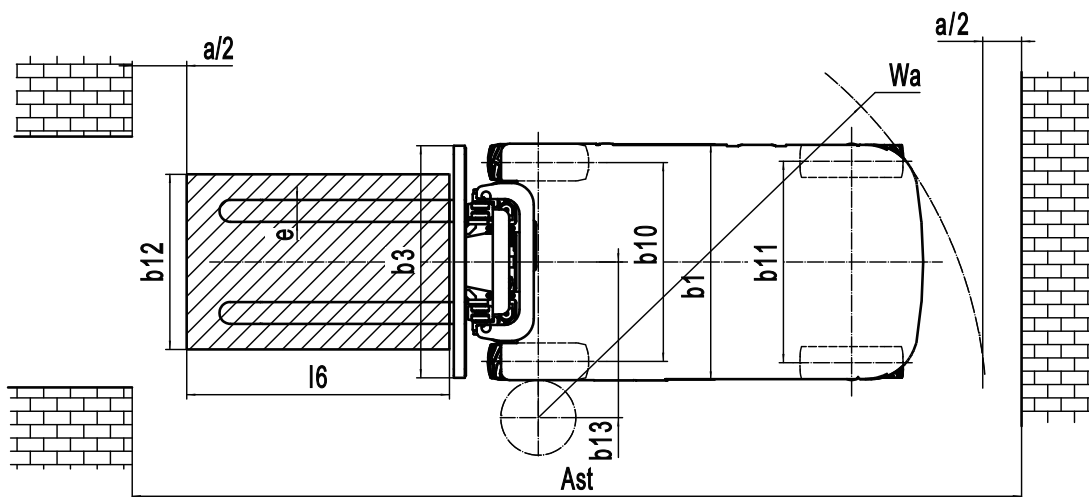
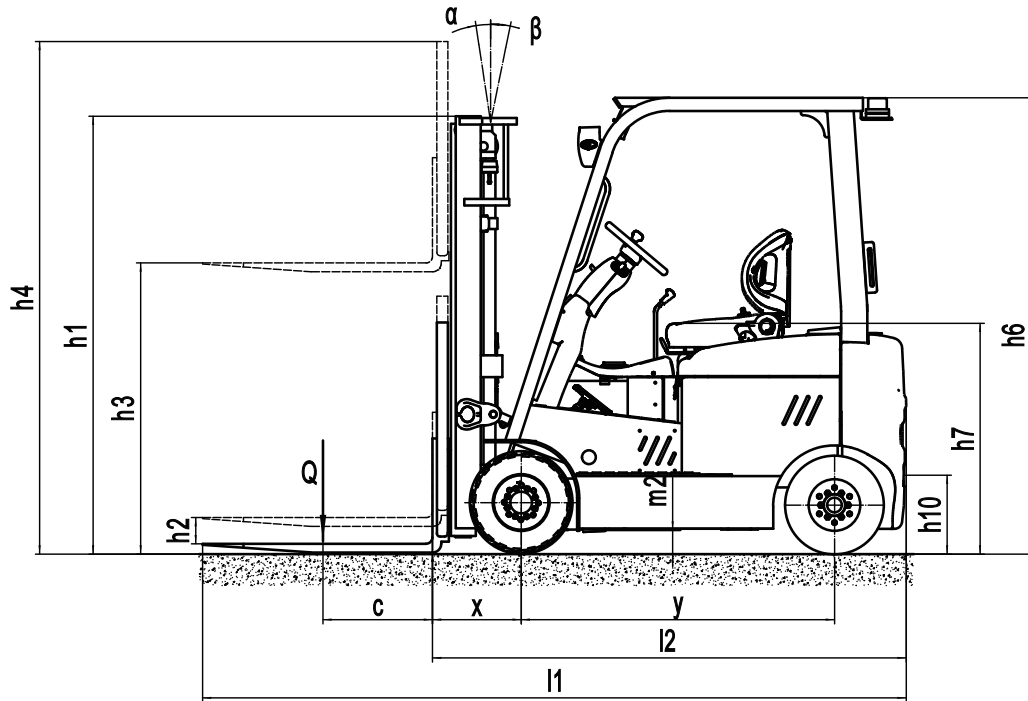

Mast Options

Mast types	Maximum Fork Height (h3) in.	Mast Dimensions			Free lift(h2)	
		Collapsed Height (h1) in.	Extended Height(h4)		No LBR in.	W/ STD. LBR in.
			No LBR in.	W/ STD. LBR in.		
3-Free Mast	189.0	84.4	208.4	229.4	65.0	44.0
	197.0	87.0	216.3	237.3	67.6	46.5