

# 4-Wheel Pneumatic Forklift

## 5,000lbs to 7,000lbs

## EFL253S/303S/353S



Let's grow together



- Heavy duty Lithium powered pneumatic series designed for rugged outdoor applications
- 80V system using EP Energy's 460Ah Lithium battery and powerful AC Drive Motors
- Ergonomic design with ample cabin space , adjustable steering, and suspension seat
- Available with enclosed cabin, AC, and heat for comfort in hot and cold environments
- Available with both onboard charging capabilities and external chargers up to 200A

Manufacturer			EP	EP	EP
Model designation			EFL253S	EFL303S	EFL353S
Drive			Electric	Electric	Electric
Base capacity	Q	lb.	5000	6000	7000
Load center distance	c	in.	24	24	24
Service weight			9520	10290	10996
Collapsed height	h1	in.	87.4	86.20	86.20
Maximum fork height	h3	in.	189	189	118.11
Height, mast extended with Std. LBR	h4	in.	229.3	232.1	232.1
Length to face of forks	l2	in.	99.61	100.00	103.07
Overall width	b1/b2	in.	45.43	47.64	47.64
Fork dimensions	s/e/l	in.	1.57x4.8x42.12	1.77x4.8x42.12	1.97x4.8x42.12
Turning radius	Wa	in.	90.75	92.4	94.68
Travel speed, loaded/unloaded			9.9/10.5	9.9/10.5	9.9/10.5
Lifting speed, loaded/unloaded			78.74/98.43	78.74/98.43	78.74/98.43
Lowering speed, loaded/unloaded			84.65/86.61	84.65/86.61	84.65/86.61
Max. gradeability, loaded/unloaded			20/25	20/25	18/25
Drive motor rating S2 60 min			17	17	17
Battery voltage/nominal capacity	V/Ah		80V460Ah	80V460Ah	80V460Ah

# Features

## Higher performance for productivity boost

Max travel speed 9.9/10.5mph to cover diverse intralogistics application needs.  
Max battery capacity 80V/460Ah and max charging current 200A for longer uptime and fast charging.  
Max gradeability 20/25% to deliver better stability on ramps.  
Max lifting speed 84.65/86.61fpm for greater efficiency



## Lithium technology to replace internal combustion engine

Lithium technology has proven itself as an emission and maintenance free alternative to internal combustion. The EFL Series features an 80v system with capacities up to 460Ah and a wide range of on-board and external chargers up to 200A.



## Ergonomic Design

The EFL features spacious legroom, simplified instrumentation, and a new LED display that clearly indicates speed, state-of-charge, machine hours and other operator information.



## Designed with the operator in mind

Our bolted overhead guard features a covered top using tempered glass and high-strength steel to maximize visibility. Outdoor comfort is enhanced with optional front windshield, semi-cab, full cabin, heater, or heater and A/C. For added flexibility, the front windshield and semi cab is available as a retrofit kit for in-field units.



# 4-wheel pneumatic forklift 5,000lbs

## EFL253S

Distinguishing mark	1.1	Manufacturer			EP	EP
	1.2	Model designation			EFL253S	EFL253S
	1.3	Drive			Electric	Electric
	1.4	Operator type			Seated	Seated
	1.5	Base capacity	Q	lb.	5000	5000
	1.6	Load center distance	c	in.	24	24
	1.8	Load distance, center of drive axle to fork	x	in.	19.49	19.49
	1.9	Wheelbase	y	in.	68.50	68.50
	Service weight	2.1	Service weight		lb.	9520
2.2		Axle loading, loaded front/rear		lb.	12665/1855	12690/1880
2.3		Axle loading, unloaded front/rear		lb.	4510/5010	4535/5035
Tires/chassis	3.1	Tire type			Solidrubber	Solidrubber
	3.2	Tire size, front			7.00-12	7.00-12
	3.3	Tire size, rear			18X7-8	18X7-8
	3.5	Wheels, number front/rear (x=drive wheels)		in.	2x2	2x2
	3.6	Tread width, front	b <sub>10</sub>	in.	38.39	38.39
	3.7	Tread width, rear	b <sub>11</sub>	in.	37.60	37.60
Dimensions	4.1	Tilt of mast/fork carriage forward/backward	$\alpha/\beta$	°	6/10	6/10
	4.2	Collapsed Height	h <sub>1</sub>	in.	87.4	90.7
	4.3	Free lift	h <sub>2</sub>	in.	47	50.4
	4.4	Maximum fork height	h <sub>3</sub>	in.	189	197
	4.5	Height, mast extended with Std. LBR	h <sub>4</sub>	in.	229.3	237.2
	4.7	Height of overhead guard (cabin)	h <sub>6</sub>	in.	85.24	85.24
	4.8	Seat height/standing height	h <sub>7</sub>	in.	43.11	43.11
	4.12	Tow coupling height	h <sub>10</sub>	in.	12.99	12.99
	4.19	Overall length	l <sub>1</sub>	in.	141.73	141.73
	4.20	Length to face of forks	l <sub>2</sub>	in.	99.61	99.61
	4.21	Overall width	b <sub>1</sub> /b <sub>2</sub>	in.	45.43	45.43
	4.22	Fork dimensions	s×e×l	in.	1.57x4.8x42.12	1.57x4.8x42.12
	4.23	A,B Fork carriage class/type A, B			2A	2A
	4.24	Fork carriage width	b <sub>3</sub>	in.	40.94	40.94
	4.31	Ground clearance, loaded, below mast	m <sub>1</sub>	in.	4.92	4.92
	4.32	Ground clearance, center of wheelbase	m <sub>2</sub>	in.	6.69	6.69
	4.34.1	Right Angle Stack (x +wa)	Ast	in.	110.24	110.24
4.34.2	Minimum Aisle Width (Right Angle Stack + Load Length + Clearance)	Ast	in.	170.24	170.24	
4.35	Turning radius	Wa	in.	90.75	90.75	
Performance data	5.1	Travel speed, loaded/unloaded		mph	9.9/10.5	9.9/10.5
	5.2	Lifting speed, loaded/unloaded		fpm	78.74/98.43	78.74/98.43
	5.3	Lowering speed, loaded/unloaded		fpm	84.65/86.61	84.65/86.61
	5.8	Max. gradeability, loaded/unloaded		%	20/25	20/25
	5.10	Service brake			Hydraulic	Hydraulic
	5.11	Parking brake			Mechanical	Mechanical
Electric-engine	6.1	Drive motor rating S2 60 min		HP	17	17
	6.2	Lift motor rating at S3 15%		kW	26	26
	6.4	Battery voltage/nominal capacity		V/Ah	80V230Ah / 80V460Ah	80V230Ah / 80V460Ah
	6.5	Minimum battery weight		lb.	597	597
Additional data	8.1	Type of drive control			AC	AC
	10.5	Steering design			Hydraulic	Hydraulic
	10.7	Sound pressure level at the driver's ear		dB(A)	< 74	< 74
	15.1	Charger output current		A	15, 35, 100, 155, 200	15, 35, 100, 155, 200

If there are improvements of technical parameters or configurations, no further notice will be given.  
The diagram shown may contain non-standard configurations.  
Minimum Aisle Width uses 48" for load length and 12" for Clearance.

# 4-wheel pneumatic forklift 6,000lbs EFL303S

Distinguishing mark	1.1	Manufacturer			EP	EP
	1.2	Model designation			EFL303S	EFL303S
	1.3	Drive			Electric	Electric
	1.4	Operator type			Seated	Seated
	1.5	Base capacity	Q	lb.	6000	6000
	1.6	Load center distance	c	in.	24	24
	1.8	Load distance, center of drive axle to fork	x	in.	18.94	18.94
	1.9	Wheelbase	y	in.	68.50	68.50
	Service weight	2.1	Service weight		lb.	10290
2.2		Axle loading, loaded front/rear		lb.	14280/2010	14305/2035
2.3		Axle loading, unloaded front/rear		lb.	4544/5746	4569/5771
Tires/chassis	3.1	Tire type			Solidrubber	Solidrubber
	3.2	Tire size, front			28X9-15	28X9-15
	3.3	Tire size, rear			200/50-10	200/50-10
	3.5	Wheels, number front/rear (x=drive wheels)		in.	2x2	2x2
	3.6	Tread width, front	b <sub>10</sub>	in.	39.76	39.76
	3.7	Tread width, rear	b <sub>11</sub>	in.	37.60	37.60
Dimensions	4.1	Tilt of mast/fork carriage forward/backward	$\alpha/\beta$	°	6/10	6/10
	4.2	Collapsed Height	h <sub>1</sub>	in.	86.2	90.9
	4.3	Free lift	h <sub>2</sub>	in.	43.1	47.8
	4.4	Maximum fork height	h <sub>3</sub>	in.	189	197
	4.5	Height, mast extended with Std. LBR	h <sub>4</sub>	in.	232.1	240
	4.7	Height of overhead guard (cabin)	h <sub>6</sub>	in.	85.83	85.83
	4.8	Seat height/standing height	h <sub>7</sub>	in.	43.70	43.70
	4.12	Tow coupling height	h <sub>10</sub>	in.	13.58	13.58
	4.19	Overall length	l <sub>1</sub>	in.	142.13	142.13
	4.20	Length to face of forks	l <sub>2</sub>	in.	100.00	100.00
	4.21	Overall width	b <sub>1</sub> /b <sub>2</sub>	in.	47.64	47.64
	4.22	Fork dimensions	s×e×l	in.	1.77x4.8x42.12	1.77x4.8x42.12
	4.23	A,B Fork carriage class/type A, B			3A	3A
	4.24	Fork carriage width	b <sub>3</sub>	in.	43.31	43.31
	4.31	Ground clearance, loaded,below mast	m <sub>1</sub>	in.	5.12	5.12
	4.32	Ground clearance, center of wheelbase	m <sub>2</sub>	in.	7.28	7.28
	4.34.1	Right Angle Stack (x +wa)	Ast	in.	111.34	111.34
4.34.2	Minimum Aisle Width (Right Angle Stack + Load Length + Clearance)	Ast	in.	171.34	171.34	
4.35	Turning radius	Wa	in.	92.40	92.40	
Performance data	5.1	Travel speed, loaded/unloaded		mph	9.9/10.5	9.9/10.5
	5.2	Lifting speed, loaded/unloaded		fpm	78.74/98.43	78.74/98.43
	5.3	Lowering speed, loaded/unloaded		fpm	84.65/86.61	84.65/86.61
	5.8	Max. gradeability, loaded/unloaded		%	20/25	20/25
	5.10	Service brake			Hydraulic	Hydraulic
	5.11	Parking brake			Mechanical	Mechanical
Electric-engine	6.1	Drive motor rating S2 60 min		kW	17	17
	6.2	Lift motor rating at S3 15%		kW	34.87	26
	6.4	Battery voltage/nominal capacity		V/Ah	80V230Ah / 80V460Ah	80V230Ah / 80V460Ah
	6.5	Minimum battery weight		lb.	597	597
Additional data	8.1	Type of drive control			AC	AC
	10.5	Steering design			Hydraulic	Hydraulic
	10.7	Sound pressure level at the driver's ear		dB(A)	< 74	< 74
	15.1	Charger output current		A	15, 35, 100, 155, 200	15, 35, 100, 155, 200

If there are improvements of technical parameters or configurations, no further notice will be given.  
The diagram shown may contain non-standard configurations.  
Minimum Aisle Width uses 48" for load length and 12" for Clearance.

# 4-wheel pneumatic forklift 7,000lbs EFL353S

Distinguishing mark	1.1	Manufacturer			EP	EP
	1.2	Model designation			EFL353S	EFL353S
	1.3	Drive			Electric	Electric
	1.4	Operator type			Seated	Seated
	1.5	Base capacity	Q	lb.	7000	7000
	1.6	Load center distance	c	in.	24	24
	1.8	Load distance, center of drive axle to fork	x	in.	19.13	19.13
	1.9	Wheelbase	y	in.	68.50	68.50
	Service weight	2.1	Service weight		lb.	10996
2.2		Axle loading, loaded front/rear		lb.	15925/2101	15950/2126
2.3		Axle loading, unloaded front/rear		lb.	4522/6474	4547/6499
Tires/chassis	3.1	Tire type			Solidrubber	Solidrubber
	3.2	Tire size, front			28X9-15	28X9-15
	3.3	Tire size, rear			200/50-10	200/50-10
	3.5	Wheels, number front/rear (x=drive wheels)		in.	2x/2	2x/2
	3.6	Tread width, front	b <sub>10</sub>	in.	39.76	39.76
	3.7	Tread width, rear	b <sub>11</sub>	in.	37.60	37.60
	Dimensions	4.1	Tilt of mast/fork carriage forward/backward	$\alpha/\beta$	°	6/10
4.2		Collapsed Height	h <sub>1</sub>	in.	86.2	90.9
4.3		Free lift	h <sub>2</sub>	in.	43.1	47.8
4.4		Maximum fork height	h <sub>3</sub>	in.	189	197
4.5		Height, mast extended with Std. LBR	h <sub>4</sub>	in.	232.1	240
4.7		Height of overhead guard (cabin)	h <sub>6</sub>	in.	85.83	85.83
4.8		Seat height/standing height	h <sub>7</sub>	in.	43.70	43.70
4.12		Tow coupling height	h <sub>10</sub>	in.	13.58	13.58
4.19		Overall length	l <sub>1</sub>	in.	145.20	145.20
4.20		Length to face of forks	l <sub>2</sub>	in.	103.07	103.07
4.21		Overall width	b <sub>1</sub> /b <sub>2</sub>	in.	47.64	47.64
4.22		Fork dimensions	s×e×l	in.	1.97x4.8x42.12	1.97x4.8x42.12
4.23		A,B Fork carriage class/type A, B			3A	3A
4.24		Fork carriage width	b <sub>3</sub>	in.	43.31	43.31
4.31		Ground clearance, loaded, below mast	m <sub>1</sub>	in.	5.12	5.12
4.32		Ground clearance, center of wheelbase	m <sub>2</sub>	in.	7.28	7.28
4.34.1		Right Angle Stack (x +wa)	Ast	in.	113.81	113.81
4.34.2	Minimum Aisle Width (Right Angle Stack + Load Length + Clearance)	Ast	in.	173.81	173.81	
4.35	Turning radius	Wa	in.	94.68	94.68	
Performance data	5.1	Travel speed, loaded/unloaded		mph	9.9/10.5	9.9/10.5
	5.2	Lifting speed, loaded/unloaded		fpm	78.74/98.43	78.74/98.43
	5.3	Lowering speed, loaded/unloaded		fpm	84.65/86.61	84.65/86.61
	5.8	Max. gradeability, loaded/unloaded		%	18/25	18/25
	5.10	Service brake			Hydraulic	Hydraulic
	5.11	Parking brake			Mechanical	Mechanical
Electric-engine	6.1	Drive motor rating S2 60 min		kW	17	17
	6.2	Lift motor rating at S3 15%		kW	26	26
	6.4	Battery voltage/nominal capacity		V/Ah	80V230Ah / 80V460Ah	80V230Ah / 80V460Ah
	6.5	Minimum battery weight		lb.	597	597
Additional data	8.1	Type of drive control			AC	AC
	10.5	Steering design			Hydraulic	Hydraulic
	10.7	Sound pressure level at the driver's ear		dB(A)	< 74	< 74
	15.1	Charger output current		A	15, 35, 100, 155, 200	15, 35, 100, 155, 200

If there are improvements of technical parameters or configurations, no further notice will be given.  
The diagram shown may contain non-standard configurations.  
Minimum Aisle Width uses 48" for load length and 12" for Clearance.

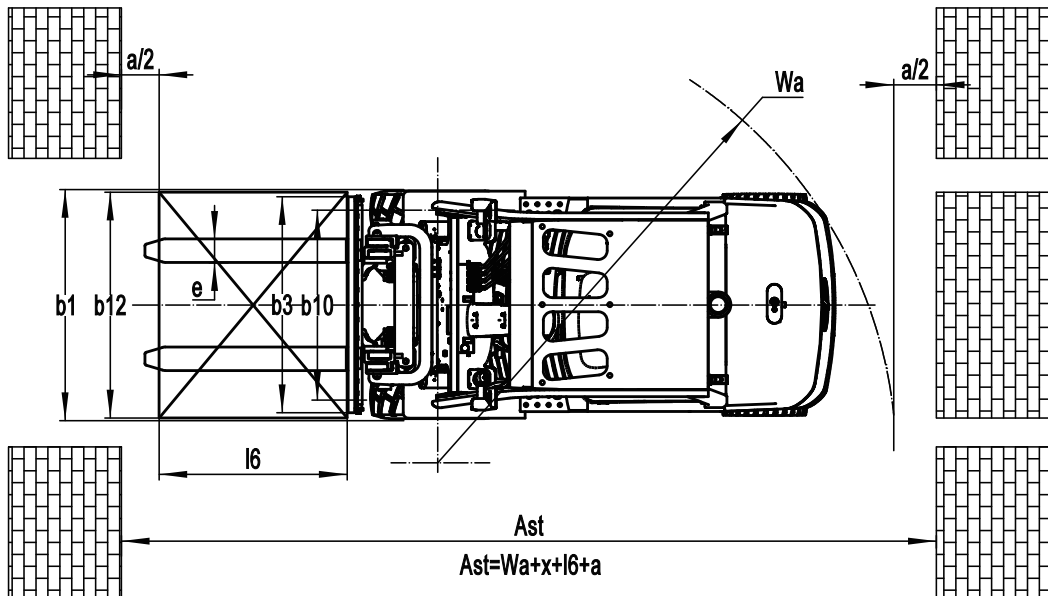
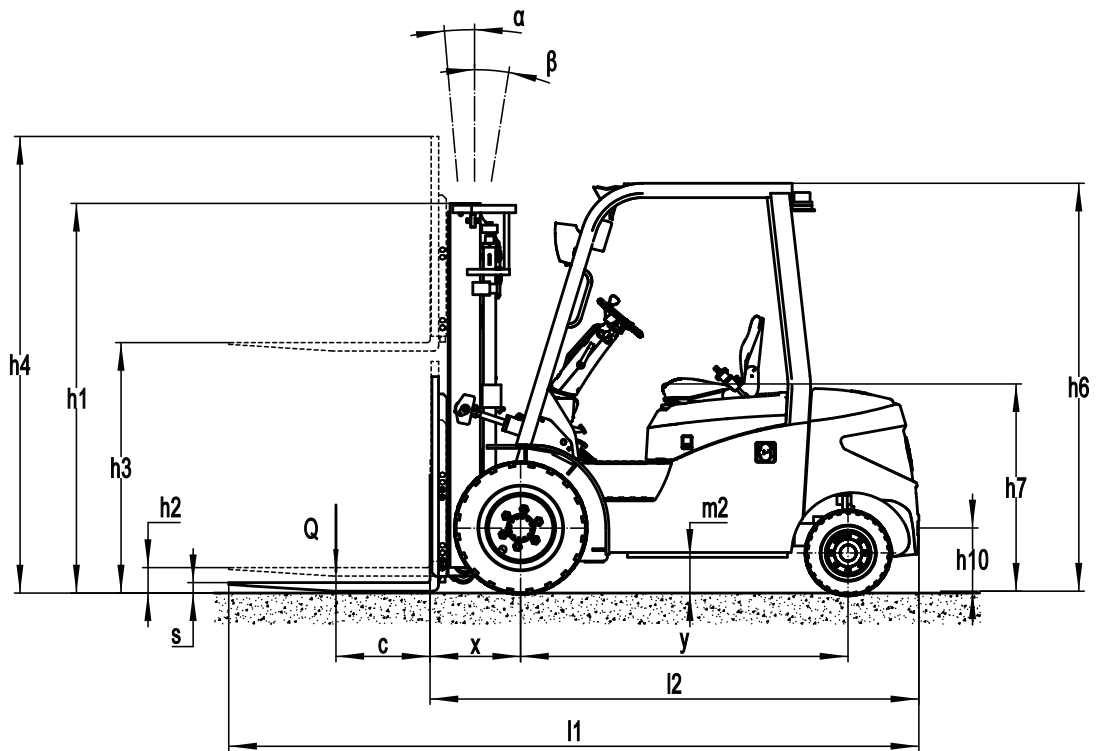

# Mast Options

## EFL253S

Mast types	Maximum Fork Height (h3)	Mast Dimensions			Free lift(h2)	
		Collapsed Height(h1)	Extended Height(h4)		No LBR	W/ STD. LBR
	No LBR		W/ STD. LBR	in.		
3-Free Mast	189.0	87.4	211.2	229.3	65.2	47.0
	197.0	90.7	219.1	237.2	68.5	50.4

## EFL303S-353S

Mast types	Maximum Fork Height (h3)	Mast Dimensions			Free lift(h2)	
		Collapsed Height(h1)	Extended Height(h4)		No LBR	W/ STD. LBR
	No LBR		W/ STD. LBR	in.		
3-Free Mast	189.0	86.2	213.8	232.1	61.4	43.1
	197.0	90.9	221.7	240.0	66.1	47.8