



# Electric Performance Straddle Stacker 3,000lbs ES14-30WA



- Lift heights from 126" to 177"
- Ergonomically designed controls and Available Side-Shift option
- Variety of battery options include AGM, Flooded, and Lithium
- Offset tiller handle provides excellent line of sight for operators
- Adjustable base legs in 4" increments

Manufacturer			EP	EP	EP
Model designation			ES14-30WA	ES14-30WA	ES14-30WA
Drive			Electric	Electric	Electric
Base capacity	Q	lb.	3000	3000	3000
Load center distance	c	in.	24	24	24
Service weight		lb.	2695	2917	3007
Collapsed height	h1	in.	83.5	72	80
Maximum fork height	h3	in.	126	157	177
Length to face of forks	l2	in.	36.5	36.5	36.5
Overall width	b1/b2	in.	50/54/58	50/54/58	50/54/58
Fork dimensions	s/e/l	in.	1.5x4x42	1.5x4x42	1.5x4x42
Turning radius	Wa	in.	60.8	60.8	60.8
Max. gradeability, loaded/unloaded		%	8/10	8/10	8/10
Travel speed, loaded/unloaded		mph	3.1/3.4	3.1/3.4	3.1/3.4
Lifting speed, loaded/unloaded		fpm	23/31	23/31	23/31
Lowering speed, loaded/unloaded		fpm	33/25	33/25	33/25
Battery voltage/nominal capacity		V/Ah	24V/170Ah, 24V/205Ah Li-ion 24V/224Ah AGM 24V/255Ah Lead-acid	24V/170Ah, 24V/205Ah Li-ion 24V/224Ah AGM 24V/255Ah Lead-acid	24V/170Ah, 24V/205Ah Li-ion 24V/224Ah AGM 24V/255Ah Lead-acid

# Electric Performance Straddle Stacker 3,000lbs

## ES14-30WA

Distinguishing mark	1.1	Manufacturer			EP	EP	EP
	1.2	Model designation			ES14-30WA	ES14-30WA	ES14-30WA
	1.3	Drive			Electric	Electric	Electric
	1.4	Operator type			Walkie	Walkie	Walkie
	1.5	Base capacity	Q	lb.	3000	3000	3000* Derate above 162"
	1.6	Load center distance	c	in.	24	24	24
	1.8	Load distance, center of drive axle to fork	x	in.	24	24	24
	1.9	Wheelbase	y	in.	53	53	53
	Service weight	2.1	Service weight		lb.	2695	2917
Tires/chassis	3.1	Tire type			Polyurethane	Polyurethane	Polyurethane
	3.2	Tire size, front			Φ9x3	Φ9x3	Φ9x3
	3.3	Tire size, rear			Φ4x2.9	Φ4x2.9	Φ4x2.9
	3.4	Additional wheels (castor wheels)		in.	Φ5x2.5	Φ5x2.5	Φ5x2.5
	3.5	Wheels, number front/rear (x=drive wheels)		in.	1x+2/4	1x + 2/4	1x + 2/4
	3.6.1	Tread width, front	b <sub>10</sub>	in.	22.8	22.8	22.8
	3.7.1	Tread width, rear	b <sub>11</sub>	in.	46/50/54	46/50/54	46/50/54
Dimensions	4.0	Max. Lift Height	H	in.	126	157	177
	4.2	Collapsed height	h <sub>1</sub>	in.	83.5	72	80
	4.3	Free lift	h <sub>2</sub>	in.	6	50	58
	4.4	Maximum fork height	h <sub>3</sub>	in.	126	157	177
	4.5	Height, mast extended with Std. LBR	h <sub>4</sub>	in.	162	193	213
	4.9	Height of tiller handle in drive position min./max.	h <sub>14</sub>	in.	39/59	39/59	39/59
	4.10	Height of wheel arms	h <sub>8</sub>	in.	3.9	4	4
	4.15	Lowered height	h <sub>13</sub>	in.	2.4	2	2
	4.19	Overall length	l <sub>1</sub>	in.	78.2	78.5	78.5
	4.20	Length to face of forks	l <sub>2</sub>	in.	36.5	36.5	36.5
	4.21	Overall width	b <sub>1</sub> /b <sub>2</sub>	in.	50/54/58	50/54/58	50/54/58
	4.22	Fork dimensions	s×e×l	in.	1.5x4x42	1.5x4x42	1.5x4x42
	4.24	Fork carriage width	b <sub>3</sub>	in.	32	32	32
	4.25	Fork spread	b <sub>5</sub>	in.	8-31	8-31	8-31
	4.26	Distance between wheel arms/loading surfaces	b <sub>4</sub>	in.	42/46/50	42/46/50	42/46/50
	4.31	Ground clearance, laden, below mast	m <sub>1</sub>	in.	3.2	3.2	3.2
4.32	Ground clearance, center of wheelbase	m <sub>2</sub>	in.	2	2	2	
4.35	Turning radius	Wa	in.	60.8	60.8	60.8	
Performance data	5.1	Travel speed, loaded/unloaded		mph	3.1/3.4	3.1/3.4	3.1/3.4
	5.2	Lifting speed, loaded/unloaded		fpm	23/31	23/31	23/31
	5.3	Lowering speed, loaded/unloaded		fpm	33/25	33/25	33/25
	5.8	Max. gradeability, loaded/unloaded		%	8/10	8/10	8/10
	5.10	Service brake			Electromagnetic	Electromagnetic	Electromagnetic
Electric-engine	6.1	Drive motor rating S2 60 min		HP	1.1	1.1	1.1
	6.2	Lift motor rating at S3 15%		HP	3	3	3
	6.4	Battery voltage/nominal capacity		V/Ah	24V/170Ah, 24V/205Ah Li-ion 24V/224Ah AGM 24V/255Ah Lead-acid	24V/170Ah, 24V/205Ah -ion 24V/224Ah AGM 24V/255Ah Lead-acid	24V/170Ah, 24V/205Ah Li-ion 24V/224Ah AGM 24V/255Ah Lead-acid
	6.5	Battery weight		lb.	340 min	340 min	340 min
	8.1	Type of drive control			AC	AC	AC
Additional data	10.5	Steering design			Mechanical	Mechanical	Mechanical
	10.7	Sound pressure level at the driver's ear		dB(A)	74	74	74
	15.1	Charger output current		A	25, 27, 80	25, 27, 80	25, 27, 80

If there are improvements of technical parameters or configurations, no further notice will be given.  
The diagram shown may contain non-standard configurations.

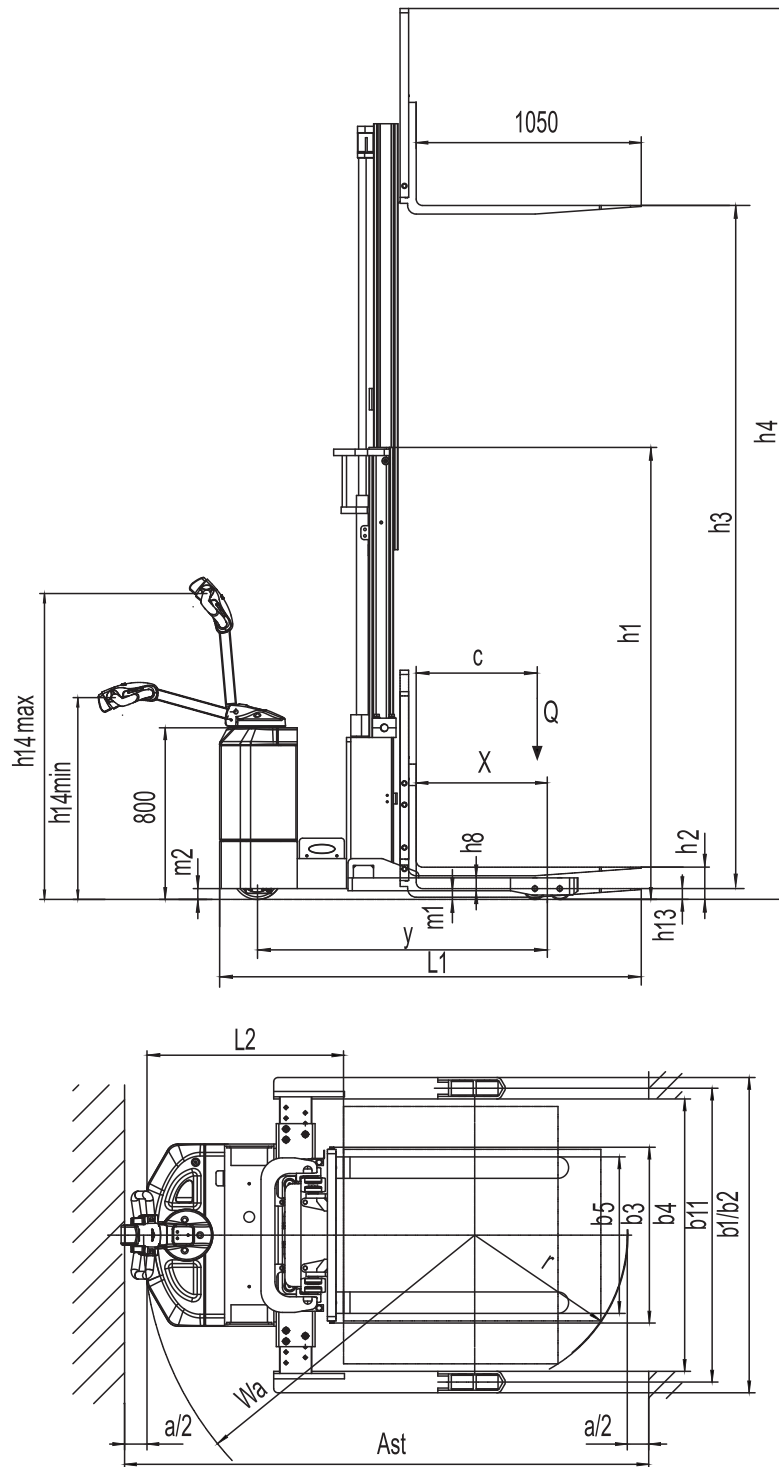

## Mast Options

Mast types	Maximum Fork Height $h3+h13$ (in)	Collapsed Height $h1$ (in)	Free lift $h2$ (in)	Extended Height $h4$ (in)
2-Wide Mast	126	83.4	5.9	162
3-Free Mast	157	71.7	35.7	193.5
	177	79.6	43.5	213.2